

Electromotoric actuator

SSA131.00, SSA331.00, SSA161.05



For pressure independent combi valves (PICV), radiator valves, MiniCombi valves (MCV) and small globe valves

- SSA131.. Operating voltage AC 24 V, 3-position control signal
- SSA331.. Operating voltage AC 230 V, 3-position control signal
- SSA161.. Operating voltage AC/DC 24 V, positioning signal DC 0...10 V
- Direct mounting with coupling nut, no tools required
- Position and actuator motion indication (LED)
- Positioning force 100 N
- Parallel operation of multiple actuators possible
- Integral cable length 1.5 m
- Load-dependent switch-off in the event of overload and in stroke end positions

Use

- For radiator valves, VDN..., VEN..., VUN..
- For Siemens PICV (pressure independent combi valves) VPP46.. and VPI46..
- For MiniCombi valves VPD..., VPE..
- For small valves VD1..CLC
- For radiator valves (M30 × 1.5) from other manufacturers without adapter
- Typically in radiator, chilled ceiling, VAV and fan coil unit applications.
- Max. 24 units of SSA131.00, 6 units of SSA331.00 or 10 units of SSA161.05 are able to operate in parallel, provided the controller output suffices.

Technical design

When the actuator is driven by DC 0...10 V control voltage or a 3-position signal, it produces a stroke, which is transmitted to the valve stem.

The description of operation in this document applies to valve versions that are fully open when valve stem is extended / no actuator is mounted (Normally Open (NO) valve).

3-position control signal (for SSA131.00 and SSA331.00 only)

- | | | |
|--------------------------------------------------------|-----------------------------------------|--------------|
| • Voltage at Y1: | Stem retracts | Valve opens |
| • Voltage at Y2: | Stem extends | Valve closes |
| • No voltage at Y1 or Y2: | Actuator maintains its current position | |
| • Voltage applied to both Y1 and Y2 (not recommended): | Actuator maintains its current position | |

DC 0...10 V control signal (for SSA161.05 only)

- The valve opens / closes in proportion to the control signal at Y.
- At DC 0 V, actuator stem extended, the valve is fully closed.
- When no power is supplied, the actuator maintains its current position.

Y = Control signal Y [V]

H = Percentage of calibrated valve stroke

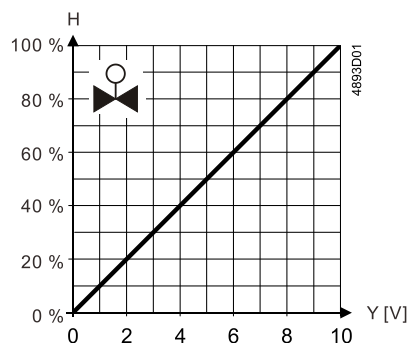

LED indication

LED colors and patterns for SSA131.00 and SSA331.00

	LED	Color	Pattern	Description
	LED 1	Green	Constant	Actuator stem is fully extended.
	LED 2	Green	Constant	Actuator stem is moving in-between.
	LED 3	Green	Constant	Actuator stem is fully retracted.

LED colors and patterns for SSA161.05

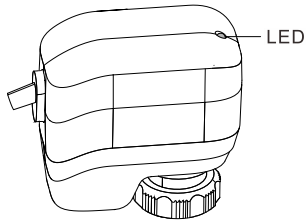
	LED color	Pattern	Flashing interval	Description	
	Green	Flashing	0.1 s	Self-calibration	
			0.5 s	Actuator stem is moving.	
	Red	Constant	-	-	Actuator stem reaches a set position. The LED turns off after it is constantly on for five seconds.
				-	Error*

* Hint: calibration or power reset required.

Type summary

Type	Stock number	Operating voltage	Running speed at 50 Hz	Running time 2.5 mm	Control signal	Cable length
SSA131.00	S55180-A106	AC 24 V	27 s/mm	67.5 s	3-position	1.5 m
SSA331.00	S55180-A105	AC 230 V	27 s/mm	67.5 s	3-position	1.5 m
SSA161.05	S55180-A107	AC/DC 24 V	10 s/mm	25 s	DC 0...10 V	1.5 m

Ordering

When ordering, specify both type and quantity.

Example:

Type	Stock number	Designation	Quantity
SSA331.00	S55180-A105	Electromotoric actuator	2

Delivery

Valves and actuators are supplied in separate packages. For easier valve assembly, the position of the actuator stem (spindle) is fully retracted.

Equipment combinations

Valves

Type reference	Valve type	K_{vs} [m ³ /h]	\dot{V} [l/h]	PN class	Data sheet
VDN..., VEN..., VUN..	Radiator valves	0.09...1.41	-	PN 10	N2105, N2106
VPD..., VPE..	MCV radiator valves	-	25...483*		N2185
VD1..CLC	Small valves	0.25...2.60	-		N2103
VPP46..., VPI46..	PICV valves DN10..DN32	-	30...4001	PN 25	N4855

Type reference	Valve type	K _{vs} [m ³ /h]	V̇ [l/h]	PN class	Data sheet
Kvs: Nominal flow rate of cold water (5...30 °C) through the fully open valve (H100) by a differential pressure of 100 kPa (1 bar)					
<i>Radiator valves (M30 × 1.5) from other manufacturers, without adapter</i>					
• Heimeier		• Crane D981..		• TA-Type TBV-C	
• Oventrop M30 × 1.5 (from 2001)		• MNG		• Junkers	
• Honeywell-Braukmann		• Cazzaniga		• Beulco (new)	

* Nominal volume flow at 0.5 mm stroke.

Note: To ensure trouble-free operation of third-party valves with the SSA.. actuator, the valves must satisfy the following requirements:

- Threaded connections with coupling nut M30 × 1.5.
- Nominal force $F \leq 100$ N
- Dimension $X \geq 8.3$ mm
- Dimension $Y \leq 14.8$ mm

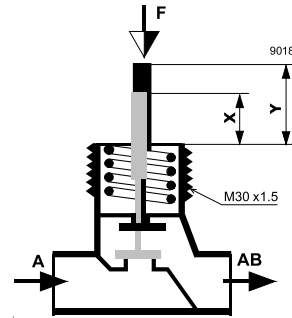

Controllers

Type	SSA131.00	SSA331.00	SSA161.05
	AC 24 V	AC 230 V	AC/DC 24 V
	3-position	3-position	DC 0...10 V
DXR2	DXR2..09T.., DXR2..10.., DXR2..11.., DXR2..12P.., DXR2..18.., DXR2..10PL..	-	DXR2..09..
RXB..	RXB21.1.., RXB24.1..	-	RXB39.1..
Synco 700 Synco 200	RMH760B-1, RMK770-1, RLU202, RLU222	-	RMU7...0B-1, RMS705B-1, RMH760B-1, RMK770-1, RLU220, RLU222, RLU232, RLU236

Room thermostats

Type	SSA131.00	SSA331.00	SSA161.05
RDG..	RDG405KN	RDG100KN, RDG100, RDG100T	RDG160KN, RDG160T, RDG405KN
RDF..	-	RDF800KN, RDF800KN/NF, RDF302, RDF600, RDF600T, RDF600KN	-
RDU..	-	-	RDU340
RCU..	-	-	RCU50..

Topic	Title	Document ID:
Mounting and installation	Mounting instructions ¹⁾	A6V11858272
Standards and directives	CE declarations	A5W00106106A
	RCM conformity	A5W00106107A
Environmental compatibility	Environmental declarations	A5W00109220A



¹⁾ The mounting instructions is enclosed in product packaging.

Related documents such as environmental declarations, CE declarations etc., can be downloaded from <http://siemens.com/bt/download>.

Notes



Engineering

The actuators must be electrically connected in accordance with local regulations (see "Connection diagrams [► 12]").

 CAUTION	
	<p>National safety regulations</p> <p>Failure to comply with national safety regulations may result in personal injury and property damage.</p> <ul style="list-style-type: none"> Observe national provisions and comply with the appropriate safety regulations.

Observe permissible temperatures (see "Technical data [► 9]"). The connecting cable of the actuator may come into contact with the hot valve body, provided the temperature of the valve body does not exceed 80 °C.

Mounting

 WARNING	
	<ul style="list-style-type: none"> Do not use pipe wrenches, spanners or similar tools. Avoid lateral pressure or (cable) tension on the mounted actuator!

Valve and actuator are easy to assemble on site before commissioning:

- Remove protective cover from the valve body.
- Position the actuator and tighten the union nut manually.
- See [Mounting instructions](#) enclosed with the product package for graphical instructions.

NOTICE	
!	The actuator must be commissioned only with a correctly mounted valve in place!

Self-calibration (SSA161.05 only)

When operating voltage is applied, the actuator self-calibrates (fully retracted → fully extended → setpoint).

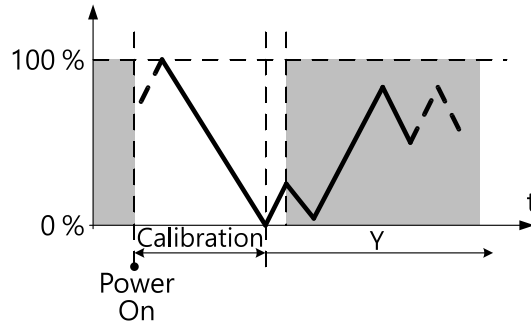

NOTICE	
!	<ul style="list-style-type: none"> • Correct calibration is only possible with valve stroke > 1.2 mm. Valve stroke < 1.2 mm results in calibration failure. • If calibration fails, the actuator performs another calibration automatically after 10 seconds. • After three failed calibration attempts, the actuator stem remains in the extended position.

Maintenance

The actuators require no maintenance.

⚠ WARNING	
	Operating voltage must be switched off during any maintenance!

NOTICE	
!	<p>When carrying out service work on the plant, note the following:</p> <ul style="list-style-type: none"> • Switch off operating voltage. • If necessary, disconnect electrical connections from the terminals. • The actuator must be commissioned only with a correctly mounted valve in place!

Repair

The actuators cannot be repaired; the complete unit must be replaced.

Disposal

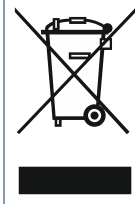

The device is considered an electronic device for disposal in accordance with European guidelines and may not be disposed of as domestic waste.

- Dispose of the device through channels provided for this purpose.
- Comply with all local and currently applicable laws and regulations.

Warranty

Technical data on specific applications are valid only together with Siemens products listed under "Equipment combinations". Siemens rejects any and all warranties in the event that third-party products are used.

Open Source Software (OSS)

Software license overview

These devices use Open Source Software (OSS). All Open Source Software components used in the product (to include copyrights and licensing agreement) are available at <http://siemens.com/bt/download>.

Firmware version	OSS document		Device
	Document ID	Title	
1.8.0	A6V12067557	Readme OSS "MRA Modulating – 1.1"	SSA161.05

Power supply					
		SSA131.00	SSA331.00	SSA161.05	
Operating voltage		AC 24 V	AC 230 V	AC 24 V	DC 24 V
Tolerance		± 20 %	± 15 %	± 15 %	± 20 %
Frequency		50/60 Hz			
Power consumption	Running	0.8 VA	7 VA	2.5 VA	
	Holding	0.2 VA	0.2 VA	2 VA	
Primary fuse or breaker rating		External, 2 A quick blow			

Signal input				
		SSA131.00	SSA331.00	SSA161.05
Control signal		3-position		DC 0...10 V
Input impedance for DC 0...10 V		-		100 kOhm
Parallel operation (number of actuators) ¹⁾		Max. 24	Max. 6	Max. 10

¹⁾ Provided that the controller output is sufficient.

Operating data				
		SSA131.00	SSA331.00	SSA161.05
Position with de-energized contact Y/Y1/Y2		See "Technical design [▶ 2]"		
Running speed at 50 Hz		27 s/mm		10 s/mm
Positioning force		100 N		
Stroke		1.2...6.5 mm		
Permissible temperature of medium in the connected valve		1...110 °C (1...90 °C for MCV-radiator valves)		

Electrical connection (connecting cable integral)				
		SSA131.00	SSA331.00	SSA161.05
Cable length		1.5 m, according to VDE 0207	1.5 m, according to IEC 60227-5	1.5 m, according to VDE 0207
Cross section of prewired connection cables		0.34 mm ² (3 ×)	0.75 mm ² (3 ×)	0.34 mm ² (3 ×)
Permissible length for signal lines		20 m		

Mounting	
Fixing on valve	Plastic coupling nut M30 × 1.5
Orientation	360°

Standards			
	SSA131.00	SSA331.00	SSA161.05
EU conformity (CE)	A5W00106106A		
RCM conformity	A5W00106107A		
Housing protection degree	IP 54		
Protection class according to EN 60730	III	II	III
Environmental compatibility	The product environmental declaration (A5W00109220A) contains data on environmentally compatible product design and assessments (RoHS compliance, materials composition, packaging, environmental benefit, disposal).		

Housing color	
Cover/base	RAL 9003, signal white
Coupling nut	RAL 7035, light gray

General ambient conditions			
	Operation EN 60721-3-3	Transport EN 60721-3-2	Storage EN 60721-3-1
Environmental conditions	Class 3K3	Class 2K3	Class 1K3
Temperature	1...50 °C	-25...70 °C	-5...50 °C
Humidity	5...85 % r.h.	<95 % r.h.	5...95 % r.h.

Material	
Cover/base	PC + ABS

Weight	
SSA131.00	216 g
SSA161.05	205 g
SSA331.00	258 g

Connection terminals

SSA131.00

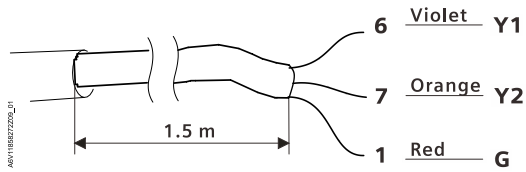

Y1 = Control signal OPEN (AC 24 V)
Y2 = Control signal CLOSE (AC 24 V)
G = System potential AC 24 V

SSA331.00

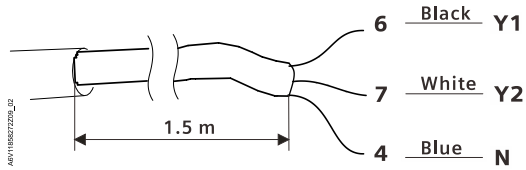

Y1 = Control signal OPEN (AC 230 V)
Y2 = Control signal CLOSE (AC 230 V)
N = Neutral

SSA161.05

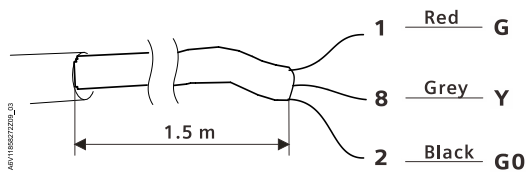

G = System potential AC 24 V (+ DC 24 V)
Y = Control signal DC 0...10 V
G0 = System neutral (- DC 24 V)

Connection diagrams

SSA131.00

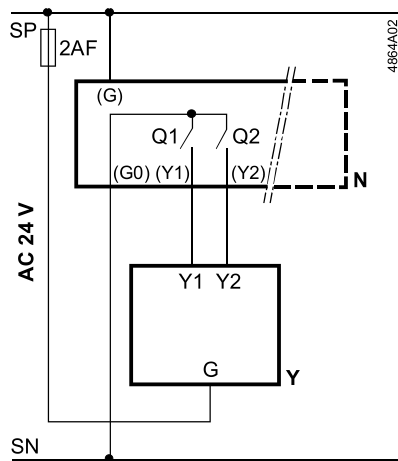

N = Controller
Y = Actuator
SP, G = System potential AC 24 V
SN, G0 = System neutral
Y1, Y2 = Control signal OPEN, CLOSE
Q1, Q2 = Controller contacts

SSA331.00

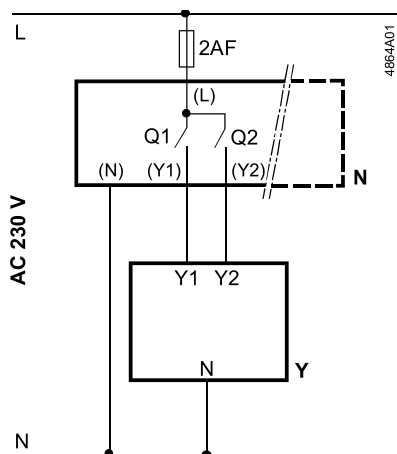

N = Controller
Y = Actuator
L = System potential AC 230 V
N = System neutral
Y1, Y2 = Control signal OPEN, CLOSE
Q1, Q2 = Controller contacts

SSA161.05

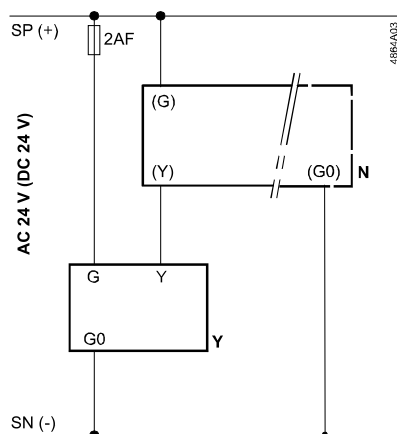

N = Controller
Y = Actuator
SP, G = System potential AC 24 V
SN, G0 = System neutral
Y = Control signal

Dimensions

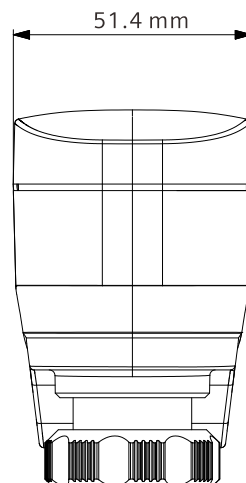
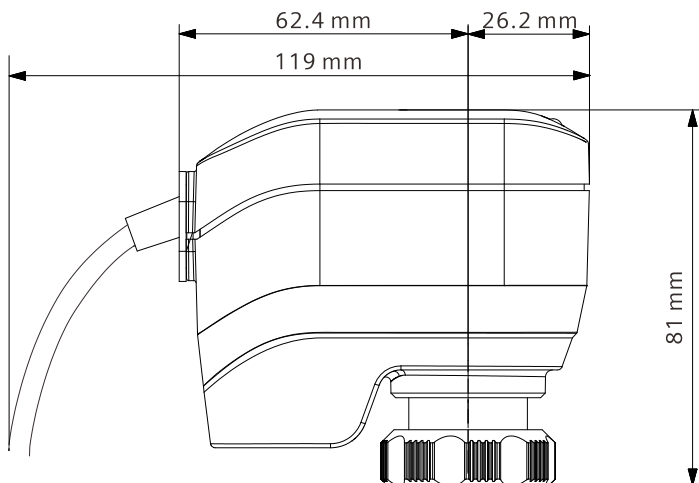

A6V11858272A02

Revision numbers

Type	Valid from rev. no.
SSA131.00	..A
SSA331.00	..A
SSA161.05	..A

Issued by
Beijing Siemens Cerberus Electronics Ltd.
Smart Infrastructure

No.1, Fengzhi East Road, Xibeiwang
Haidian District, 100094 BEIJING, China
+86 10 64768806
www.siemens.com/buildingtechnologies

© Beijing Siemens Cerberus Electronics Ltd., 2021
Technical specifications and availability subject to change without notice.

Document ID A6V11858276_en--_f
Edition 2022-03-23