

Cloud capable and communicative rotary actuator for ball valves

- Torque motor 40 Nm
- Nominal voltage AC/DC 24 V
- Control modulating, communicative, hybrid, Cloud
- Conversion of sensor signals
- Ethernet 10/100 Mbit/s, TCP/IP, integrated web server
- Communication via BACnet IP, Modbus TCP and Cloud

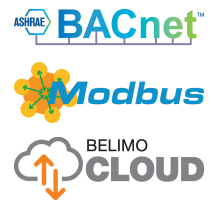

Technical data

| | | | |
|-------------------------------|----------------------------------------|------------------------------------------------------------------------------|---------------|
| Electrical data | Nominal voltage | AC/DC 24 V | |
| | Nominal voltage frequency | 50/60 Hz | |
| | Nominal voltage range | AC 19.2...28.8 V / DC 21.6...28.8 V | |
| | Power consumption in operation | 5.5 W | |
| | Power consumption in rest position | 1.5 W | |
| | Power consumption for wire sizing | 8 VA | |
| | Connection supply / control | Cable 1 m, 6 x 0.5 mm ² | |
| | Connection Ethernet | RJ45 socket | |
| | Parallel operation | Yes (note the performance data) | |
| Data bus communication | Communicative control | Cloud BACnet IP Modbus TCP | |
| | Number of nodes | BACnet / Modbus see interface description | |
| Functional data | Torque motor | 40 Nm | |
| | Operating range Y | 2...10 V | |
| | Input Impedance | 34 kΩ | |
| | Operating range Y variable | 0.5...10 V | |
| | Position accuracy | ±5% | |
| | Manual override | with push-button, can be locked | |
| | Running time motor | 90 s / 90° | |
| | Running time motor variable | 75...270 s | |
| | Adaptation setting range | manual | |
| | Sound power level, motor | 45 dB(A) | |
| Position indication | Mechanically, pluggable | | |
| Safety data | Protection class IEC/EN | III, Safety Extra-Low Voltage (SELV) | |
| | Degree of protection IEC/EN | IP40 IP54 when using protective cap or protective grommet for RJ45 socket | |
| | EMC | CE according to 2014/30/EU | |
| | Mode of operation | Type 1 | |
| | Rated impulse voltage supply / control | 0.8 kV | |
| | Pollution degree | 3 | |
| | Ambient humidity | Max. 95% RH, non-condensing | |
| | Ambient temperature | -30...50°C [-22...122°F] | |
| | Storage temperature | -40...80°C [-40...176°F] | |
| | Servicing | maintenance-free | |
| | Mechanical data | Connection flange | F05 |
| | | Weight | Weight |
| | | 2.3 kg | |

Safety notes



- This device has been designed for use in stationary heating, ventilation and air-conditioning systems and must not be used outside the specified field of application, especially in aircraft or in any other airborne means of transport.
- Outdoor application: only possible in case that no (sea) water, snow, ice, insolation or aggressive gases interfere directly with the device and that it is ensured that the ambient conditions remain within the thresholds according to the data sheet at any time.
- Only authorised specialists may carry out installation. All applicable legal or institutional installation regulations must be complied during installation.
- The device may only be opened at the manufacturer's site. It does not contain any parts that can be replaced or repaired by the user.
- Cables must not be removed from the device.
- To calculate the torque required, the specifications supplied by the damper manufacturers concerning the cross-section, the design, the installation situation and the ventilation conditions must be observed.
- The device contains electrical and electronic components and must not be disposed of as household refuse. All locally valid regulations and requirements must be observed.

Product features

Mode of operation The actuator is controlled via the Cloud, BACnet IP or Modbus TCP and drives to the position defined by the control signal. Various data points can be written and read via the same interfaces.

Hybrid mode:

The actuator receives its analog control signal from the higher level controller and drives to the position defined. Using the Cloud, BACnet IP or Modbus TCP, various data points can be read and with the exception of the control signal written.

Converter for sensors Connection option for two sensors (passive sensor, active sensor or switching contact). The actuator serves as an analogue/digital converter for the transmission of the sensor signal to the higher level system.

Communication The parametrisation can be carried out through the integrated web server (RJ45 connection to the web browser), by communicative means or via the Cloud.

Additional information regarding the integrated web server can be found in the separate documentation.

"Peer to Peer" connection

<http://belimo.local:8080>

The Notebook must be set to "DHCP".

Make sure that only one network connection is active.

Standard IP address:

<http://192.168.0.10:8080>

Static IP address

Password (read-only):

User name: «guest»

Password: «guest»

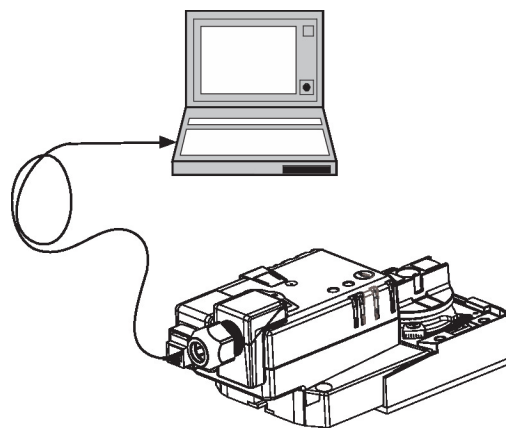

Simple direct mounting Simple direct mounting on the rotary valve or butterfly valve with mounting flange. The mounting orientation in relation to the fitting can be selected in 90° steps.

Data recording The recorded data (integrated data recording for 13 months) can be used for analytical purposes.

Download csv files via web browser.

Manual override Manual override with push-button possible (the gear train is disengaged for as long as the button is pressed or remains locked).

- Adjustable angle of rotation** Adjustable angle of rotation with mechanical end stops.
- High functional reliability** The actuator is overload protected, requires no limit switches and automatically stops when the end stop is reached.
- Home position** The first time the supply voltage is switched on, i.e. at the time of commissioning, the actuator carries out an adaptation, which is when the operating range and position feedback adjust themselves to the mechanical setting range.
The actuator then moves into the position defined by the control signal.
- Adaptation and synchronisation** An adaptation can be triggered manually by pressing the "Adaptation" button. Both mechanical end stops are detected during the adaptation (entire setting range).
The actuator then moves into the position defined by the control signal.

Accessories

| Electrical accessories | Description | Type |
|------------------------|-----------------------------------------------------------------------------------------------------------------------------------------|----------|
| | Grommet for RJ connection module, Multipack 50 pcs. | Z-STRJ.1 |
| Tools | Description | Type |
| | Service Tool, with ZIP-USB function, for parametrisable and communicative Belimo actuators, VAV controller and HVAC performance devices | ZTH EU |
| | Connection cable 5 m, A: RJ11 6/4 ZTH EU, B: 6-pin for connection to service socket | ZK1-GEN |

Electrical installation



Supply from isolating transformer.
Parallel connection of other actuators possible. Observe the performance data.

Wiring diagrams

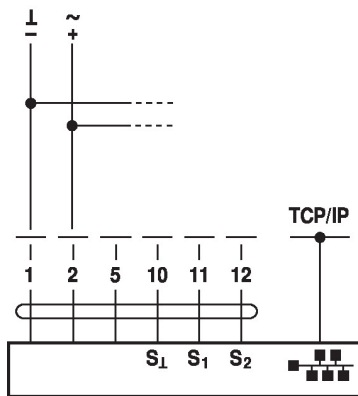
AC/DC 24 V

Cable colours:

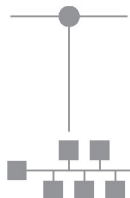
- 1 = black
- 2 = red
- 5 = orange
- 10 = yellow-black
- 11 = yellow-pink
- 12 = yellow-grey

Web-Browser

Connection of a notebook for parametrisation and manual control via RJ45.

Optional connection via RJ45 (direct connection Notebook / connection via Intranet or Internet) for access to the integrated web server

Functions



The connection diagrams shows connections for the first sensor on terminal S1, while the second sensor can be connected identically on terminal S2.
 Parallel use of different sensor types is permitted.
 For hybrid operation, S1 is used for the control signal Y and must be configured as an active sensor.

Functions with specific parameters (parametrisation necessary)

TCP/IP (Cloud) / BACnet IP / Modbus TCP

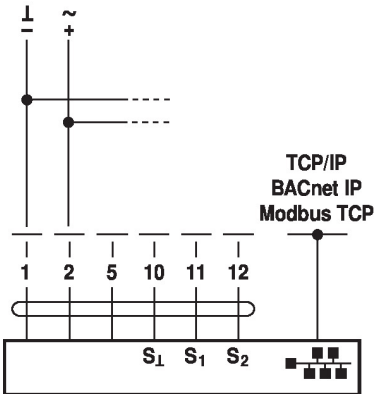

Connection of passive sensors

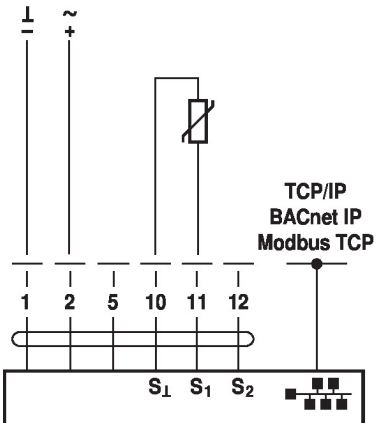

Switching contact connection

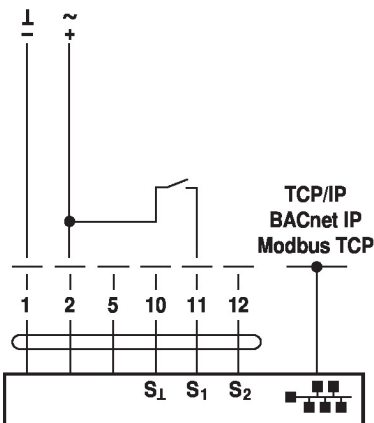

TCP/IP (Cloud) / BACnet IP / Modbus TCP with analogue setpoint (hybrid operation)

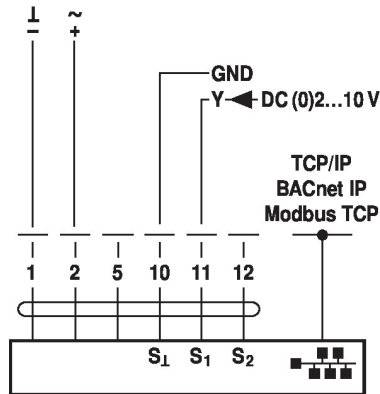

Connection of active sensors

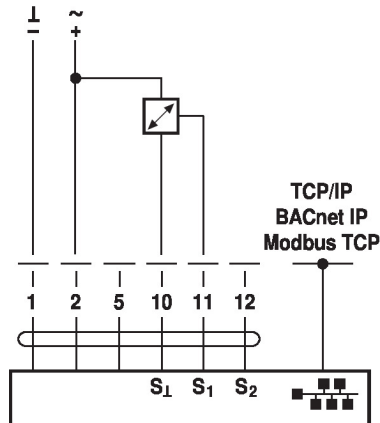

Operating controls and indicators

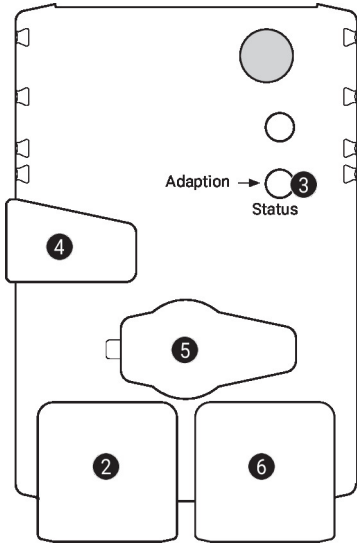

2 LED display green

- Off: No power supply or wiring error
- On: Actuator starts operation
- Flickering: In operation

3 Push-button and LED display yellow

- Off: Standard mode
- On: Adaptation or synchronisation process active
- Press: Triggers angle of rotation adaptation, followed by standard mode button:

4 Manual override button

- Press button: Gear train disengages, motor stops, manual override possible
- Release button: Gear train engages, standard mode

5 Service plug

For connecting parametrisation and service tools

6 RJ45 socket

For the connection of TCP/IP (Cloud), BACnet IP and Modbus TCP

Dimensions

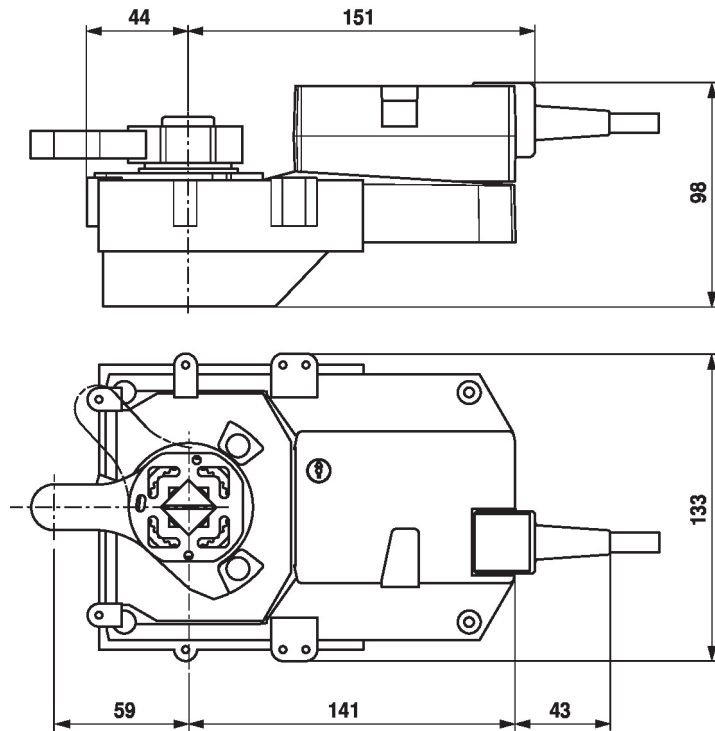

Further documentation

- General notes for project planning
- Instruction Webserver
- BACnet Interface description
- Modbus Interface description
- Description clientAPI