

Frost monitor

For monitoring the temperatures of water/air heaters in ventilation and air-conditioning systems to prevent frost damage to the heating registers. Equipped with an active capillary tube, the frost monitors continuously signal the frost hazard with a signal output DC 0...10 V (start-up function) and via a 1-pole potential-free changeover.

Type Overview

Type	Output signal active temperature	Output signal temperature switch	Additional features	Capillary
20DTS-1P3	0...10 V	Changeover	Auto or manual reset	2 m
20DTS-1P5	0...10 V	Changeover	Auto or manual reset	6 m

Technical data

Electrical data	Nominal voltage	AC 24 V	
	Nominal voltage range	AC 19.2...26.4 V	
	Power consumption AC	6.6 VA	
	Electrical connection	Spring loaded terminal max. 2.5 mm ²	
	Cable entry	Cable gland with strain relief M16x1.5 mm, for cable Ø4.5...10 mm	
Functional data	Application	Air	
	Output signal active note	Temperature sensor: 0...10 V (± 0...15°C) Valve control: 0...10 V (max. 1 mA)	
	Output signal temperature switch note	max. switching current 6(2) A @ AC 230 V / 6A @ DC 24 V	
	Switching reliability	Min. switching current 100 mA @ AC 12 V	
	Analogue Input	0...10 V (max. 1 mA)	
	Display	LED, 2-digit segment display	
Measuring data	Measured values	Temperature	
	Measuring range temperature	0...15°C [32...59°F] Default setting: 5°C [41°F]	
	Adjustment range Temperature	1...10°C	
	Switching differential (temperature)	Typ. 2 K	
	Long-term stability	2 K according to DIN EN 14597	
	Time constant τ (63%) in air duct	Typical 90 s @ 0 m/s Typical 40 s @ 0.2 m/s	
	Materials	Cable gland	PA6, black
		Housing	Bottom: PA (RAL 7001, silver grey) Cover: PA, transparent Cover cap: ABS
Capillary		Copper	
Safety data	Ambient humidity	Max. 85% RH, non-condensing	
	Ambient temperature	-15...55°C [-5...130°F]	

Safety data	Fluid temperature	Up to max. 110°C
	Storage temperature	-25...65°C [-13...149°F]
	Protection class IEC/EN	III, Safety Extra-Low Voltage (SELV)
	EU Conformity	CE Marking
	Degree of protection IEC/EN	IP42
	EMC	DIN EN 61326-1
	Quality Standard	ISO 9001

Safety notes

This device has been designed for use in stationary heating, ventilation and air-conditioning systems and must not be used outside the specified field of application. Unauthorised modifications are prohibited. The product must not be used in relation with any equipment that in case of a failure may threaten humans, animals or assets.

Ensure all power is disconnected before installing. Do not connect to live/operating equipment.

Only authorised specialists may carry out installation. All applicable legal or institutional installation regulations must be complied during installation.

The device contains electrical and electronic components and must not be disposed of as household refuse. All locally valid regulations and requirements must be observed.



During installation, testing, servicing and troubleshooting of this product, it may be necessary to work with live electrical components. Have a qualified licensed electrician or other individual who has been properly trained in handling live electrical components perform these tasks. Failure to follow all electrical safety precautions when exposed to live electrical components could result in death or serious injury.

Product Features

- Mode of operation** With the help of a vapor-filled capillary tube and diaphragm, the frost detector acquires the lowest temperature which occurs along at least 250 mm length of capillary tubing.
- The 20DTS-1.. performs its task by providing 3 independent functions:
1. It opens the heating valve continuously within a proportional control range. (AOU2 DC 0...10 V, terminal 5)
 2. It switches off the fans and closes the air dampers via its relay contact.
 3. It makes the acquired temperature available for further handling. (AOU1 DC 0...10 V, terminal 2)
- The measuring signal is then used as a frost signal by the frost detector and for valve control. The frost signal starts rising at about 6 K above the adjusted frost value.

Function chart of startup function

The frost signal is added to the valve control signal (terminal 4) fed to signal input Y. This causes the heating valve to travel to its fully open position – resulting from the control signal received via signal output AOU2 – before the output relay changes to the "Frost" position (terminal S2 - S3). This circuitry prevents frequent switching of the plant during the startup phase.

To make certain it is always the lowest temperature along the capillary tube that is acquired, the temperature of the diaphragm inside the housing must always be higher than the temperature at the capillary tube. This is ensured by a heating element inside the housing, which maintains the temperature at the diaphragm above 15 °C as long as the ambient temperature does not fall below -15 °C.

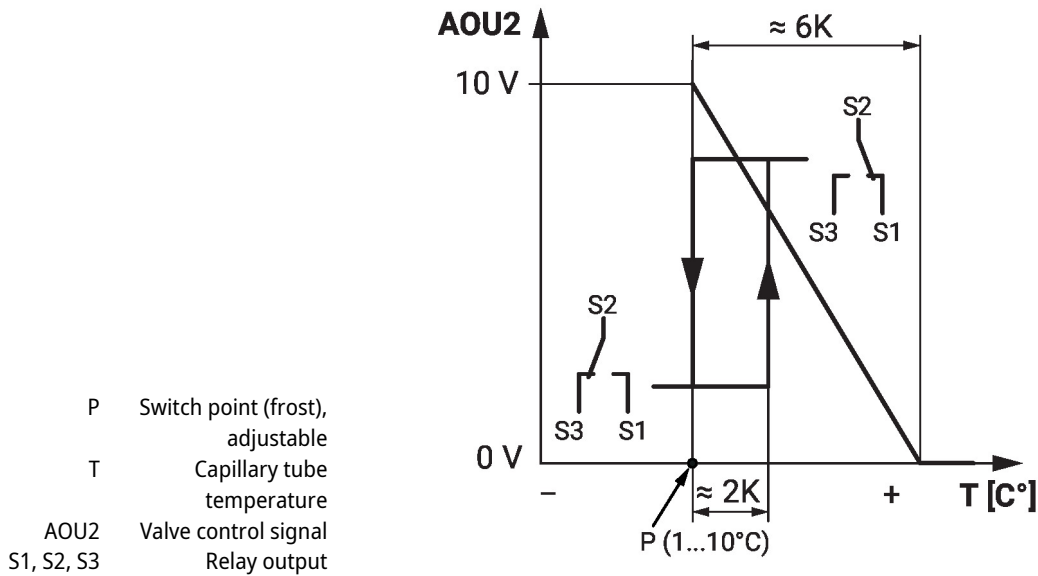

Operating modes Three operating modes can be selected:

Automatic operation 'Auto'

If, after shutdown due to frost, the capillary tube temperature rises (>2 K), the output relay will automatically return to its normal position.

Manual operation 'Manu'

If, after shutdown due to frost, the capillary tube temperature rises (>2 K), the output relay will return to its normal position only if either the inbuilt reset button is pressed or the power supply is cut off (e.g. via an external reset button).

Test mode 'Test'

In test mode, the output relay is forced to the "Frost" position. The valve control signal AOU2 (terminal 5) will not be affected. When returning to the switch position 'Manu', the frost position is maintained. It must be cancelled by pressing the reset button.

Functional check
Test mode

Pressing the button (3) or (4) for more than 2 seconds selects test mode. The display screen shows 'tE' alternating with the set switching point. The output relay switches to frost position (S2 - S3 closed).

The valve control signal AOU2 (terminal 5) is not affected.

Test mode is switched off by pressing button (3) or (4) for more than 2 seconds or by interrupting the voltage supply.

Checking the probe function

Set the switching point based on the current probe line temperature.

If required: cool the function loop or another piece of the probe line (at least 250 mm long) to below the set switching point.

The relay contact must switch and the LED (1) must light up.

The measurement signal voltage can be measured at terminals 1 and 2 (see wiring diagram) (measuring range: DC 0...10 V \pm 0...15°C).

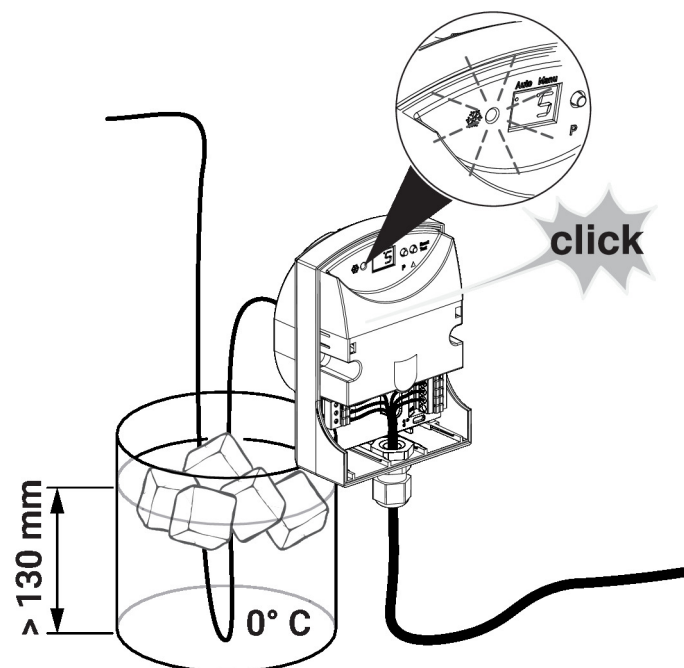
Unlocking in frost position

In 'Auto' operating mode, the frost monitor is automatically unlocked as soon as the temperature rises by approx. 2 K above the switching point.

In 'Manu' operating mode, the frost monitor is locked in the frost position. It can be unlocked by pressing the button (3), (4) or by interrupting the voltage supply.

Indicating a fault

If the frost monitor has stopped functioning due to a fault in the probe line (fracture in the capillary tube), the device switches to frost mode, the relay has also switched and the LED (1) lights up.

If the voltage supply is correct, the display flashes '- -'.

Operating controls and indicators

Operating elements Settings are made via the two buttons ③ and ④.

- ① LED red (danger of frost)
- ② Display screen for switching point (P) and operating mode
- ③ Parameter button
- ④ Value / Reset button

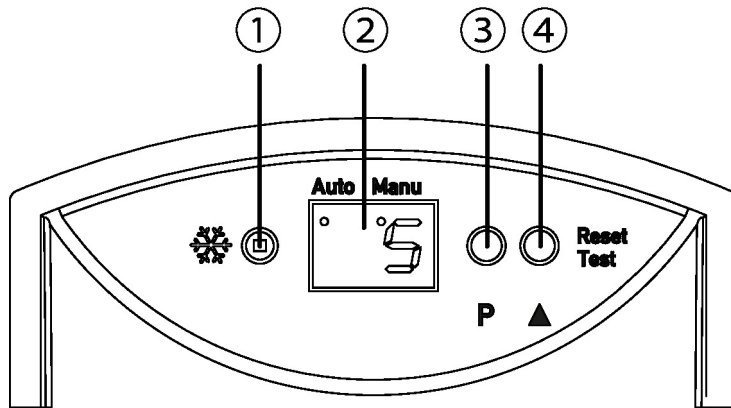

Setting switching point frost (Sp)

Adjustment switching point (Sp)

By pressing the button (3) (on display appears SP) once and then selecting the switching point frost using the button (4).

Values are rotational, automatic transfer of values after 2 seconds.

Setting operating mode (St)

Operating mode (St)

By pressing the button (3) twice and then selecting the operating mode using the button (4). Automatic unlocking 'At' (function as temperature monitor). Manual unlocking 'Hd' (function as temperature limiter).

Values are rotational, automatic transfer of values after 2 seconds.

Automatic unlocking

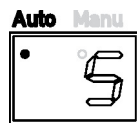

Manual unlocking



Scope of delivery

Scope of delivery	Description	Type
	Mounting kit, with 6 mounting brackets	A-22D-A08

Accessories

Optional accessories air	Description	Type
	Mounting flange for frost guard 20DTS-..., Plastic	A-22D-A12

Wiring diagram

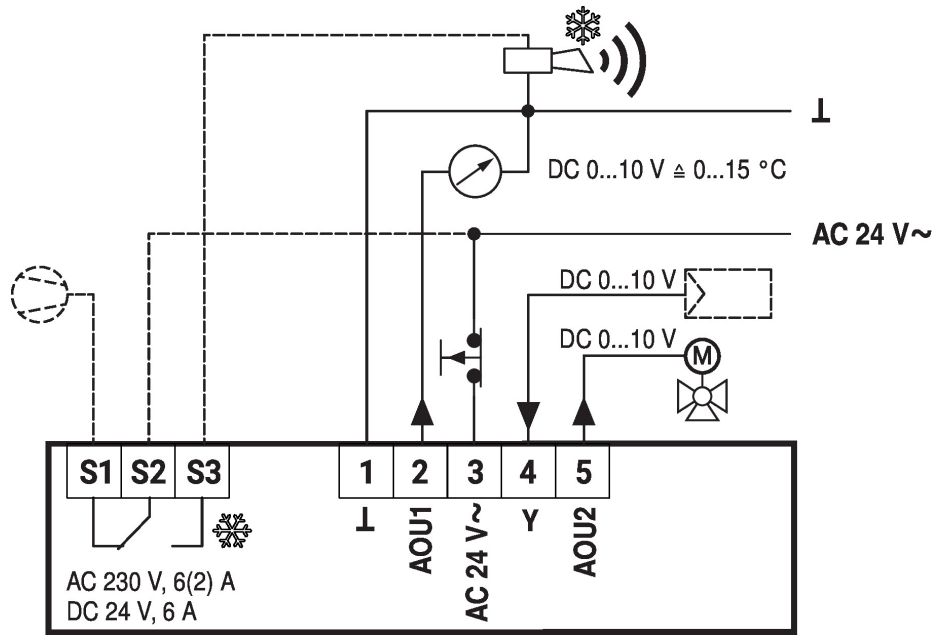

If the capillary leaks, the switch changes to the frost position.
 Min. active length material of capillary tube is 250 mm.
 Permissible cable length at 1.5 mm² diameter is max. 300 m.

Dimensions

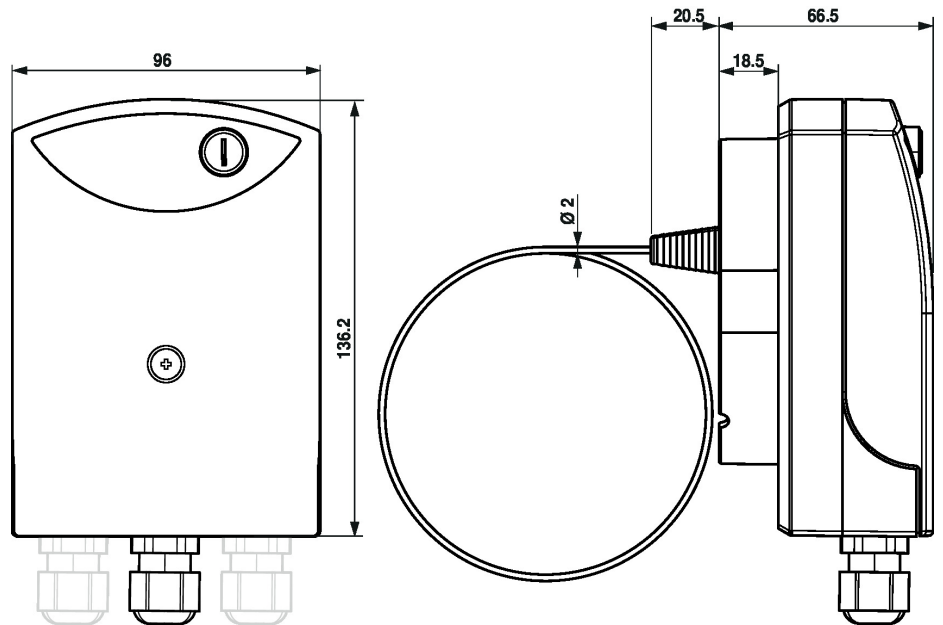

Type	Weight
20DTS-1P3	0.16 kg
20DTS-1P5	0.36 kg