

» FTK+ (LCD) RS485 BACnet

Duct sensor for humidity and temperatur

thermokon[®]
HOME OF SENSOR TECHNOLOGY

Datasheet

Subject to technical alteration
Issue date: 28.02.2022 • A112



Illustration similar

» APPLICATION

Duct sensor for measuring humidity and temperature in gaseous media of heating, ventilation and air-conditioning systems. In delivery condition, the sensor is designed for measuring temperature and relative humidity. Alternatively the output can be set to absolute humidity, enthalpy or dew point (depending on the model, changeable via jumper or using Thermokon USEapp). LCD models with RGB background light have a transparent cover. Display configuration and threshold values for color changes can be parameterized via Thermokon USEapp. A mounting flange and fixing material are included in delivery.

» TYPES AVAILABLE

Duct humidity sensor temperature_+ humidity optional with display– active RS485 BACnet MS/TP

FTK+ 140 (LCD) RS485 BACnet incl. MF20

FTK+ 270 (LCD) RS485 BACnet incl. MF20

FTK+ 400 (LCD) RS485 BACnet incl. MF20

» SECURITY ADVICE – CAUTION



The installation and assembly of electrical equipment should only be performed by authorized personnel.

The product should only be used for the intended application. Unauthorised modifications are prohibited! The product must not be used in relation with any equipment that in case of a failure may threaten, directly or indirectly, human health or life or result in danger to human beings, animals or assets. Ensure all power is disconnected before installing. Do not connect to live/operating equipment.

Please comply with

- Local laws, health & safety regulations, technical standards and regulations
- Condition of the device at the time of installation, to ensure safe installation
- This data sheet and installation manual

» PRODUCT TESTING AND CERTIFICATION



Declaration of conformity

The declaration of conformity of the products can be found on our website <https://www.thermokon.de/>.

» NOTES ON DISPOSAL



As a component of a large-scale fixed installation, Thermokon products are intended to be used permanently as part of a building or a structure at a pre-defined and dedicated location, hence the Waste Electrical and Electronic Act (WEEE) is not applicable. However, most of the products may contain valuable materials that should be recycled and not disposed of as domestic waste. Please note the relevant regulations for local disposal.

» BUILD-UP OF SELF-HEATING BY ELECTRICAL DISSIPATIVE POWER

Temperature sensors with electronic components always have a dissipative power, which affects the temperature measurement of the ambient air. The dissipation in active temperature sensors shows a linear increase with rising operating voltage. This dissipative power has to be considered when measuring temperature. In case of a fixed operating voltage ($\pm 0,2$ V) this is normally done by adding or reducing a constant offset value. As Thermokon transducers work with a variable operating voltage, only one operating voltage can be taken into consideration, for reasons of production engineering. Transducers 0..10 V / 4..20 mA have a standard setting at an operating voltage of 24 V =. That means, that at this voltage, the expected measuring error of the output signal will be the least. For other operating voltages, the offset error will be increased by a changing power loss of the sensor electronics. If a re-calibration should become necessary later directly on the sensor, this can be done by means of the USEapp software and an optional Bluetooth interface.

Remark: Occurring draft leads to a better carrying-off of dissipative power at the sensor. Thus temporally limited fluctuations might occur upon temperature measurement.

» APPLICATION NOTICE FOR HUMIDITY SENSORS

Refrain from touching the sensitive humidity sensor/element. Touching the sensitive surface will void warranty. For standard environmental conditions re-calibration is recommended once a year to maintain the specified accuracy. When exposed to high ambient temperature and/or high levels of humidity or presence of aggressive gases (i.e. chlorine, ozone, ammonia) the sensor element may be affected and re-calibration may be required sooner than specified. Re-calibration and deterioration of the humidity sensor due to environmental conditions are not subject of the general warranty.

» TECHNICAL DATA

Measuring values	temperature, humidity (humidity output configurable)	
Output voltage	2x 0..10 V or 0..5 V, min. load 10 k Ω (live-zero configuration via Thermokon USEapp)	
Network technology	RS485 BACnet MS/TP	
Power supply	15..35 V = or 19..29 V ~ SELV <i>With alternating voltage, the correct polarity must be ensured</i>	
Power consumption	max. 2,5 W (24 V =) 4,3 VA (24 V ~)	
Measuring range temp.	-20..+80 °C (default setting), optionally configured via Thermokon USEapp	
Measuring range humidity	0..100% rH non-condensing, optionally configured via Thermokon USEapp (enthalpy, absolute humidity, dew point)	
Accuracy temperature	$\pm 0,3$ K (typ. at 21 °C)	
Accuracy humidity	$\pm 2\%$ between 10..90% rH (typ. at 21 °C)	
Air speed	max. 12 m/s	
Display (optional)	LCD 29x35 mm with RGB backlight	
Enclosure	enclosure USE-M, PC, pure white, cover PC, transparent, with removable cable entry	
Protection	IP65 according to EN 60529	
Cable entry	M25 for cable max. $\varnothing=7$ mm, seal insert for fourfold cable entry	
Connection electrical	Mainboard removable plug-in terminal, max. 2,5 mm ²	Plug-in card removable plug-in terminal, max. 1,5 mm ²
Pipe	PA6, black, $\varnothing=19,5$ mm, length=140 270 400 mm	
Filter	stainless steel wire mesh	
Ambient condition	enclosure with LCD -20..+70 °C, max. 85% rH short term condensation	enclosure without LCD -35..+70 °C, max. 85% rH short term condensation

When several BUS devices are supplied by one 24 V AC voltage supply, it is to be ensured that all "positive" operating voltage input terminals (+) of the field devices are connected and all "negative" operating voltage input terminals (-) (=reference potential) are connected (in-phase connection of field devices). In the case of reversed polarity at one field device, a supply voltage short-circuit would be caused by that device.

The consequential short-circuit current flowing through this field may cause damage to it. Therefore, pay attention to correct wiring.

» USE ENCLOSURE WITH UV AND WEATHER RESISTANCE

After some time, outdoor mounted plastics can lose their color and quality. Therefore, all USE housings are made of special white polycarbonate (PC). The light-stable colorants and additives are used to achieve optimum protection of the polymer while maintaining color stability. The titanium dioxide used is specially developed for polycarbonate and offers excellent UV protection through the reflection of the entire light spectrum including the UV component by 340 nm. This effectively counteracts the otherwise occurring photochemical polymer degradation. The colors stay full for a long time without fading. The material is also resistant to cold and frost.

» CONFIGURATION



The Thermokon bluetooth dongle with micro-USB is required for communication between USEapp and USE-M / USE L (Item No.: 668262). Commercial bluetooth dongles are not compatible.



Application-specific reconfiguration of the devices can be carried out using the Thermokon USEapp. The configuration is carried out in the voltage-supplied state.



The configuration-app and the app description can be found in the Google Play Store or in the Apple App Store.

» APPLICATION NOTICE



The housing cover must be completely closed in order to ensure the accuracy and reproducibility of the measured values during a test or service log via USEapp.

The Bluetooth dongle snaps into the socket easily. When removing, please fix the plug-in card (option PCB) so that it is not unintentionally pulled out.

After a certain time, dirt in the air can collect on the filter and then adversely affect the operation of the sensor. Under normal ambient condition an annual maintenance is recommended. Rinse the filter after cleaning with distilled water and dry it using clean oil-free air or nitrogen. Extremely contaminated filters should be replaced. At extreme ambient conditions, e.g. corrosive gases, the humidity sensor may have to be changed.

» MOUNTING ADVICES

The sensor can be mounted on the ventilation duct by means of the mounting flange MF20 TPO (optional with mounting base).

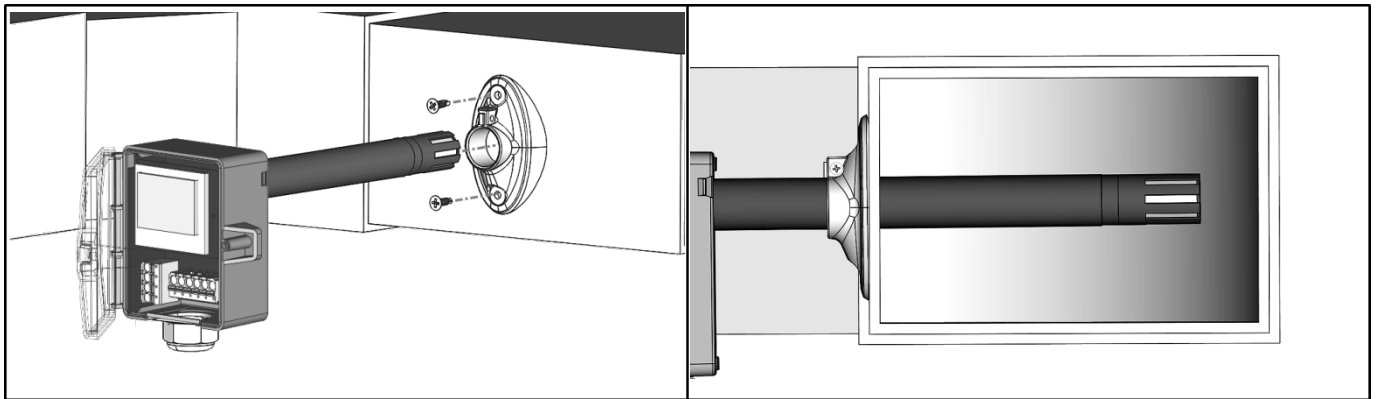

optional:

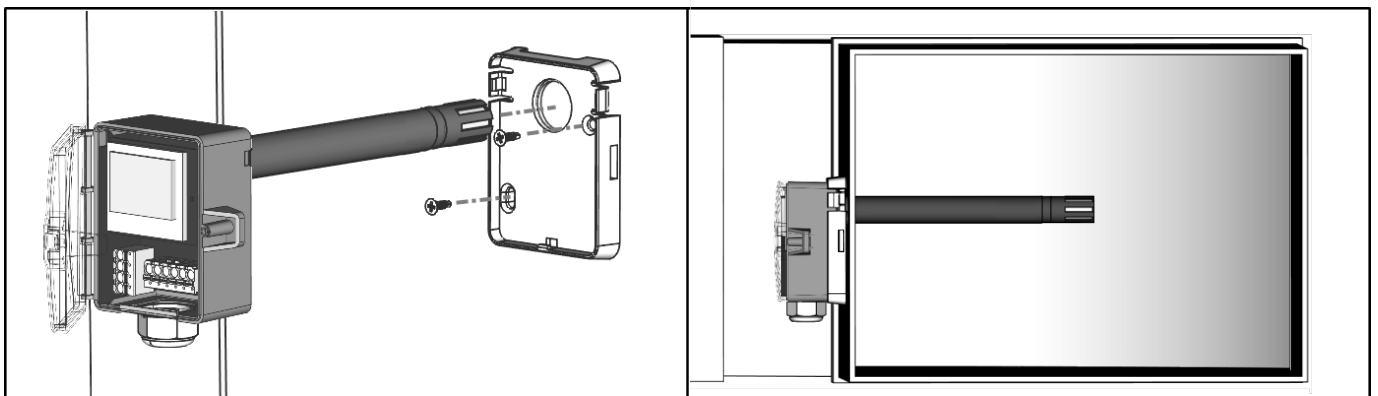

» **CONNECTION PLAN**

To change the output voltage range (default 0..10 V to 0..5 V) via jumper, the display must be removed from the board first.

FTK+ (LCD) **RS485**

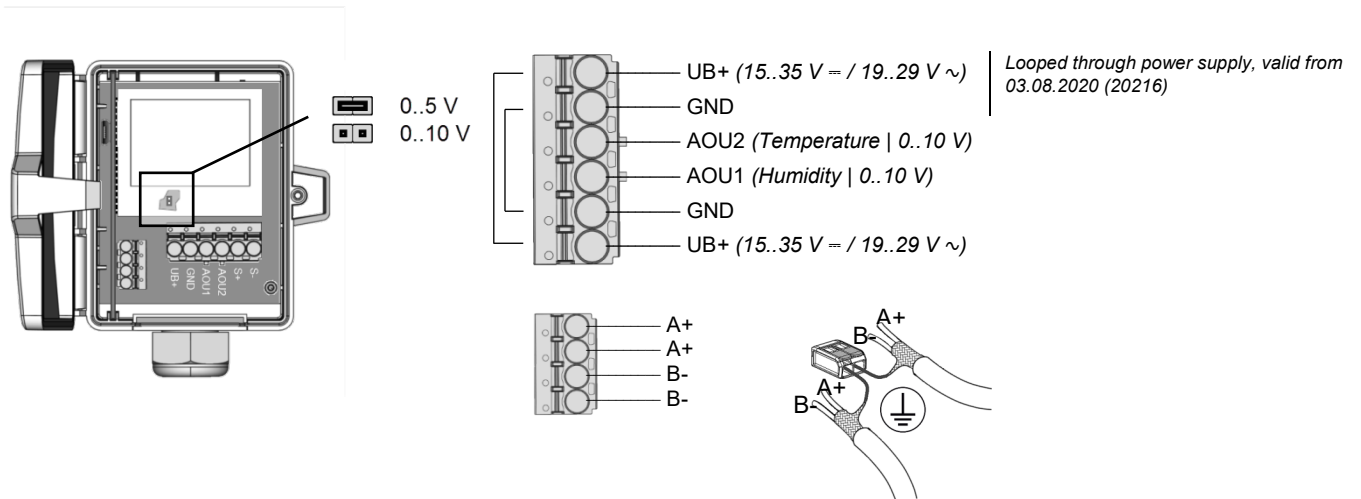

The BACnet address of the device is set binary coded in the range of 1 ... 127 via 7 dip-switches. (the address 0 is reserved and cannot be selected).



BACnet Objects:
USE-RS485 BACnet interface

A detailed description of the BACnet interface can be found at the following link:
→ [Download](#)

Address block 1

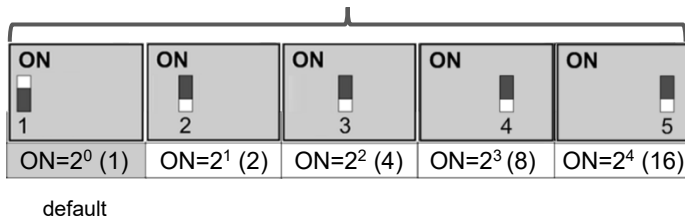

default

Termination 120Ω

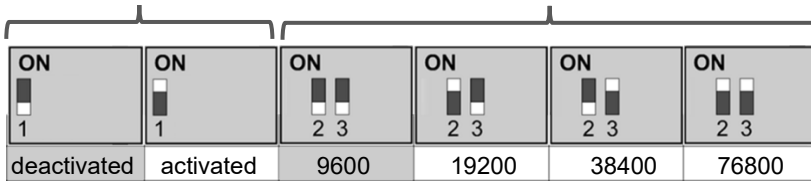

default

default

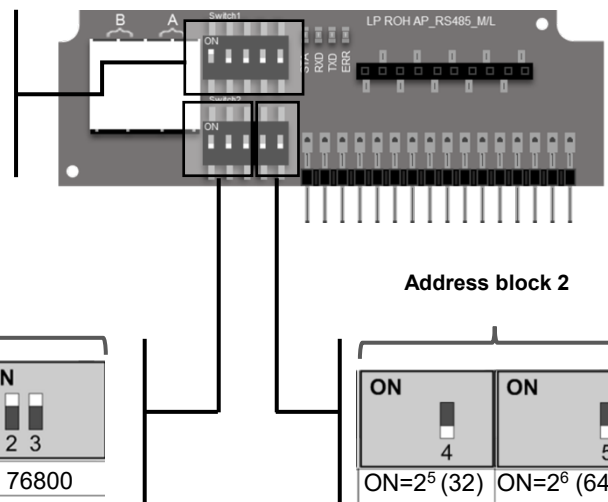

Address block 2

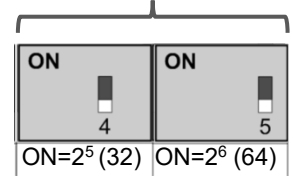

Measuring values

Objects	Access	Description	Unit
AI-1	R	relative Humidity	%rH

Object AV-38 = 1 (Unit SI)

Objects	Access	Description	Unit
AI-0	R	temperature	SI °C
AI-2	R	absolute humidity	SI g/m³
AI-3	R	enthalpy	SI KJ/kg
AI-4	R	dew point	SI °C

Object AV-38 = 2 (Unit Imperial)

Objects	Access	Description	Unit	
AI-0	R	temperature	Imperial	°F
AI-2	R	absolute humidity	Imperial	gr/ft ³
AI-3	R	enthalpy	Imperial	BTU/lb
Ai-4	R	dew point	Imperial	°F

» DIMENSIONS (MM)

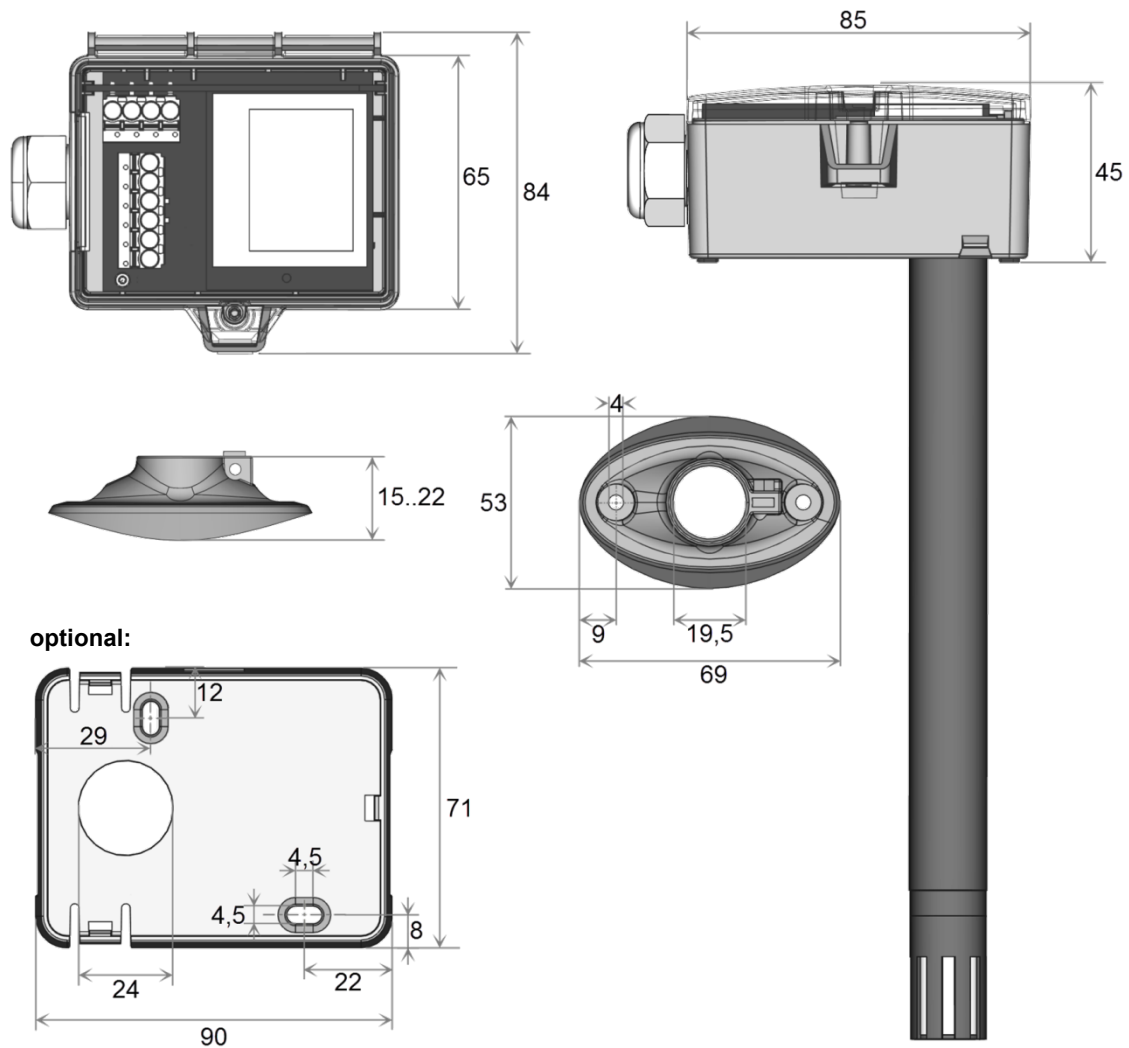

» ACCESSORIES (INCLUDED IN DELIVERY)

Mounting flange MF20 TPO
 Mounting kit universal
 • Cover screw + screw cover • 2 Rawlplugs • 2 Screws (countersunk head) • 2 Screws (rounded head)

Item No. 612562
 Item No. 698511

» ACCESSORIES (OPTIONAL)

Mounting base
 Filter stainless steel, wire mesh

Item No. 631228
 Item No. 231169