

## » FT-RDF18+ RS485 Modbus

Room sensor temperature and humidity, flush mounting at ceiling

**thermokon**<sup>®</sup>  
HOME OF SENSOR TECHNOLOGY

### Datasheet

Subject to technical alteration  
Issue date: 16.09.2021 • A120

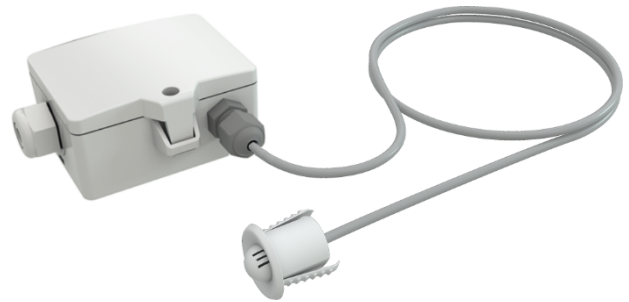

### » APPLICATION

Ceiling sensor for unobtrusive humidity and temperature measurement in the ceiling area of room and office spaces. Designed for control and monitoring applications.

### » TYPES AVAILABLE

#### Ceiling sensor temperature + humidity – active BUS

- FT-RDF18+ RS485 Modbus

#### Ceiling sensor with display temperature + humidity – active BUS

- FT-RDF18+ LCD RS485 Modbus

### » SECURITY ADVICE – CAUTION



The installation and assembly of electrical equipment should only be performed by authorized personnel.

The product should only be used for the intended application. Unauthorised modifications are prohibited! The product must not be used in relation with any equipment that in case of a failure may threaten, directly or indirectly, human health or life or result in danger to human beings, animals or assets. Ensure all power is disconnected before installing. Do not connect to live/operating equipment.

Please comply with

- Local laws, health & safety regulations, technical standards and regulations
- Condition of the device at the time of installation, to ensure safe installation
- This data sheet and installation manual

### » NOTES ON DISPOSAL



As a component of a large-scale fixed installation, Thermokon products are intended to be used permanently as part of a building or a structure at a pre-defined and dedicated location, hence the Waste Electrical and Electronic Act (WEEE) is not applicable. However, most of the products may contain valuable materials that should be recycled and not disposed of as domestic waste. Please note the relevant regulations for local disposal.

## » BUILD-UP OF SELF-HEATING BY ELECTRICAL DISSIPATIVE POWER

Temperature sensors with electronic components always have a dissipative power, which affects the temperature measurement of the ambient air. The dissipation in active temperature sensors shows a linear increase with rising operating voltage. This dissipative power has to be considered when measuring temperature. In case of a fixed operating voltage ( $\pm 0,2$  V) this is normally done by adding or reducing a constant offset value. As Thermokon transducers work with a variable operating voltage, only one operating voltage can be taken into consideration, for reasons of production engineering. Transducers 0..10 V / 4..20 mA have a standard setting at an operating voltage of 24 V =. That means, that at this voltage, the expected measuring error of the output signal will be the least. For other operating voltages, the offset error will be increased by a changing power loss of the sensor electronics. If a re-calibration should become necessary later directly on the sensor, this can be done by means of a trimming potentiometer on the sensor board.

**Remark: Occurring draft leads to a better carrying-off of dissipative power at the sensor. Thus temporally limited fluctuations might occur upon temperature measurement.**

## » APPLICATION NOTICE FOR HUMIDITY SENSORS

**Refrain from touching the sensitive humidity sensor/element. Touching the sensitive surface will void warranty.**

For standard environmental conditions re-calibration is recommended once a year to maintain the specified accuracy.

When exposed to high ambient temperature and/or high levels of humidity or presence of aggressive gases (i.e. chlorine, ozone, ammonia) the sensor element may be affected and re-calibration may be required sooner than specified. Re-calibration and deterioration of the humidity sensor due to environmental conditions are not subject of the general warranty.

## » TECHNICAL DATA

|                          |  |   |
|--------------------------|--|---|
| Measuring values         | temperature, humidity (humidity output configurable)   |   |
| Output voltage           | 2x 0..10 V or 0..5 V, min. load 10 k $\Omega$ (live-zero configuration via Thermokon USEapp)   |   |
| Network technology       | RS485 Modbus, RTU, half-duplex, baud rate 9.600, 19.200, 38.400 or 57600, parity: none (2 stopbits), even or odd (1 stopbit)   |   |
| Power supply             | 15..35 V = or 19..29 V ~ SELV<br><i>With alternating voltage, the correct polarity must be ensured</i>   |   |
| Power consumption        | max. 0,4 W (24 V =)   0,8 VA (24 V ~)  |   |
| Measuring range temp.    | -20..+80 °C (default setting), optionally configurable via Thermokon USEapp  |   |
| Measuring range humidity | 0..100% rH non-condensing, optionally configurable via Thermokon USEapp (enthalpy, absolute humidity, dew point)   |   |
| Accuracy temperature     | $\pm 0,3$ K (typ. at 21 °C)  |   |
| Accuracy humidity        | $\pm 2\%$ between 10..90% rH (typ. at 21 °C)   |   |
| Display (optional)       | LCD 29x35 mm with RGB backlight  |   |
| Enclosure                | enclosure USE-M, PC, pure white, with removable cable entry  | <b>with LCD Display (optional)</b><br>cover PC, transparent |
| Protection               | <b>enclosure</b><br>IP65 according to EN 60529   | <b>sensor head</b><br>IP30 according to EN 60529            |
| Cable entry              | M25 for cable max. $\varnothing=7$ mm, seal insert for fourfold cable entry  |   |
| Connection electrical    | removable plug-in terminal (Mainboard: max. 2,5 mm <sup>2</sup> / Plug-in card: max 1,5 mm <sup>2</sup> );<br>connection wire sensor head to plug RJ12: PVC 0,15 m;<br>connection wire bush RJ12 to enclosure: PVC 3 m |   |
| Sensor head              | ABS, white, $\varnothing=30$ mm  |   |
| Ambient condition        | -35..+70 °C, short term condensation   |   |

*When several BUS devices are supplied by one 24 V AC voltage supply, it is to be ensured that all "positive" operating voltage input terminals (+) of the field devices are connected and all "negative" operating voltage input terminals (-) (=reference potential) are connected (in-phase connection of field devices). In the case of reversed polarity at one field device, a supply voltage short-circuit would be caused by that device.*

**The consequential short-circuit current flowing through this field may cause damage to it. Therefore, pay attention to correct wiring.**

## » PRODUCT TESTING AND CERTIFICATION



### Declaration of conformity

The declaration of conformity of the products can be found on our website <https://www.thermokon.de/>.

» **CONNECTION PLAN**

If the RS485 cable is looped through, connect both cable shields using the enclosed 2-pol. Connect terminal as shown.

**FT\_RDF18+ RS485 Modbus**

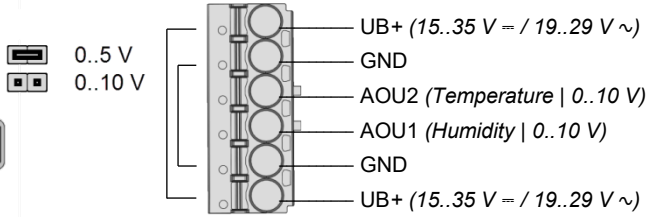
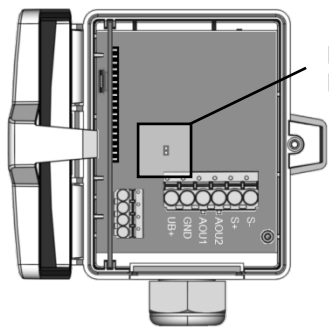

Looped through power supply, valid from 03.08.2020 (20216)

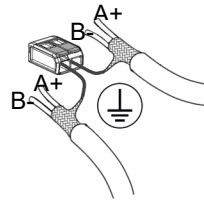
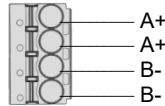

**Modbus address**

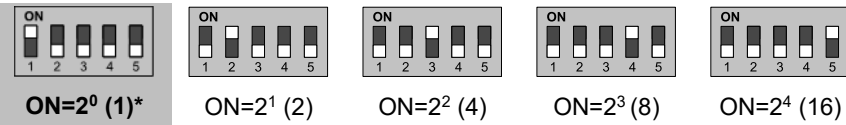

The modbus address of the device is set in the range of 1 ... 31 (binary encoded) using a 5-pole DIP switch. With address 0 via DIP, an extended address range (32..247) is available via USEapp.

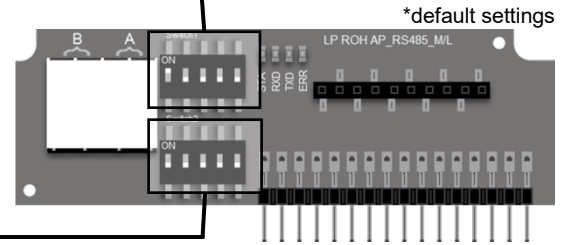

**termination 120 Ω**



**baud rate**

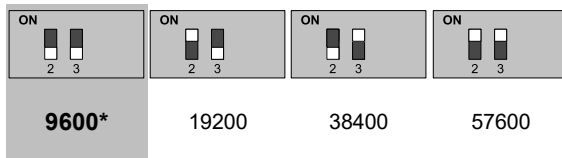

**parity**

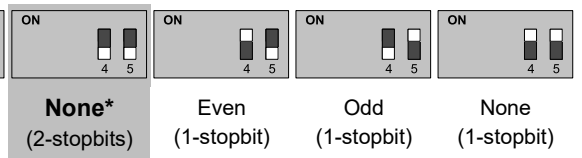

| Address | Access | Description       | Resolution / Unit |
|---------|--------|-------------------|-------------------|
| 1       | R      | relative humidity | 0.1 %rF           |

**Register 400 = 1 (Unit SI)**

| Address | Access | Description       | Resolution / Unit |
|---------|--------|-------------------|-------------------|
| 0       | R      | Temperature       | SI 0.1 °C         |
| 2       | R      | Absolute humidity | SI 0.01 g/m³      |
| 3       | R      | Enthalpy          | SI 0.1 kJ/kg      |
| 4       | R      | Dew point         | SI 0.1 °C         |

**Register 400 = 2 (Unit Imperial)**

| Address | Access | Description       | Resolution / Unit    |
|---------|--------|-------------------|----------------------|
| 0       | R      | Temperature       | Imperial 0.1 °F      |
| 2       | R      | Absolute humidity | Imperial 0.01 gr/ft³ |
| 3       | R      | Enthalpy          | Imperial 0.1 BTU/lb  |
| 4       | R      | Dew point         | Imperial 0.1 °F      |



**Modbus addresses:**  
USE-RS485 Modbus Interface

A detailed description of the Modbus addresses can be found under the following link:  
→ [Download](#)

## » DIMENSIONS (MM)

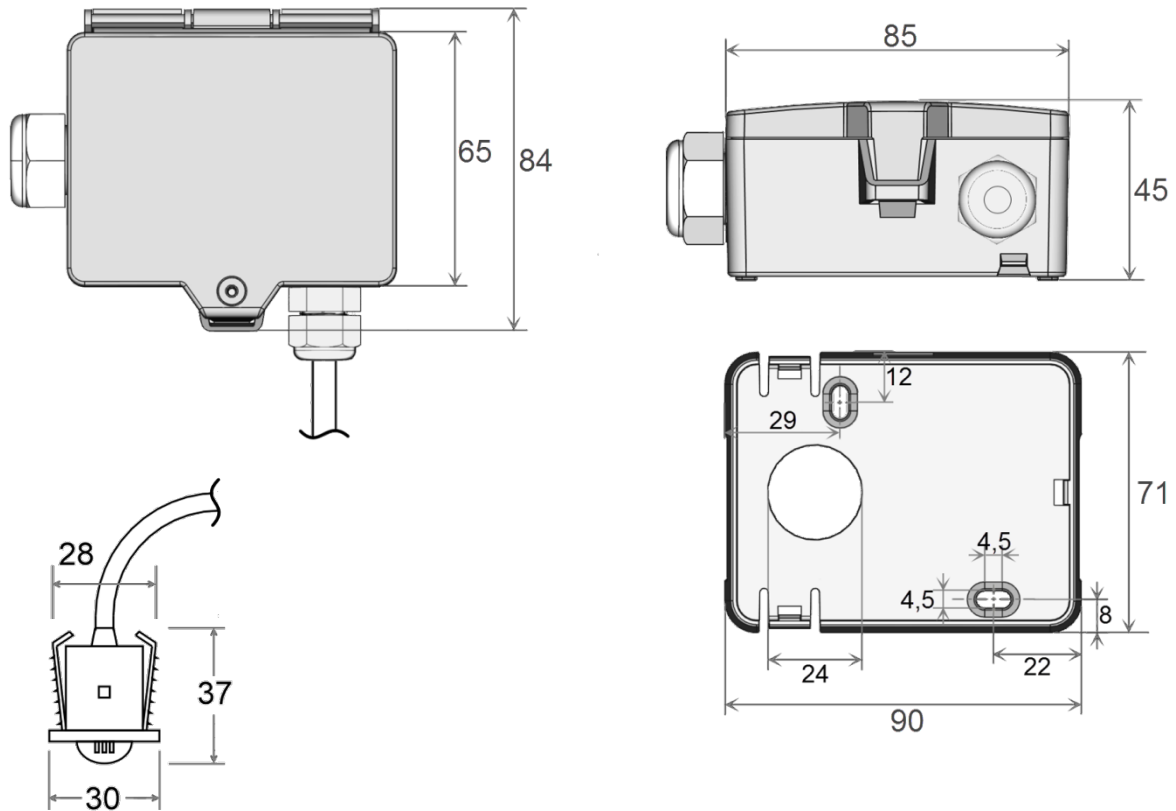

## » ACCESSORIES (INCLUDED IN DELIVERY)

Mounting base

Item No. 631228

Mounting kit universal

Item No. 698511

• Cover screw + screw cover • 2 Rawlplugs • 2 Screws (countersunk head) • 2 Screws (rounded head)

## » ACCESSORIES (OPTIONAL)

Cable entry M25 USE white, sealing insert 4x  $\varnothing=7$  mm (4 pcs)

Item No. 641364

Filter stainless steel, wire mesh

Item No. 231169

**M16 Sealing inserts cable entry (packaging unit 10 pcs.)**

|                             |        |
|-----------------------------|--------|
| for wire with $\varnothing$ | 8 mm   |
| Item No                     | 641340 |