

» DPA+ (LCD) RS485 BACnet

Differential Pressure Transmitter

thermokon[®]
HOME OF SENSOR TECHNOLOGY

Datasheet

Subject to technical alteration
Issue date: 14.08.2020 • A110

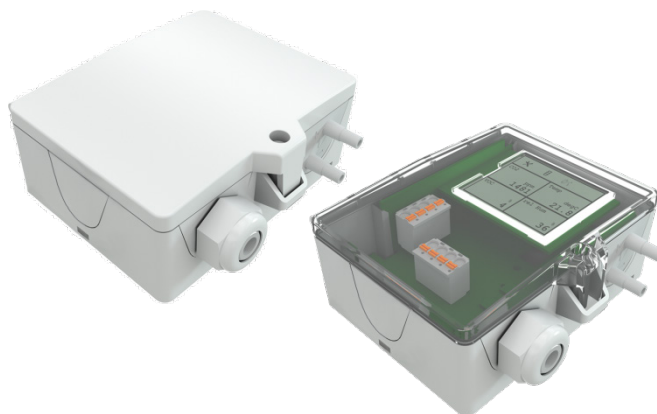

The following illustrations show the version with LCD

» APPLICATION

Differential pressure and volume flow transducer for monitoring differential pressure and volume flow of air and other non-flammable and non-aggressive gases. Three types with eight different measuring ranges are available for different applications. In addition to differential pressure all variants provide the calculated volume flow as second analog output signal. LCD models with RGB background light have a transparent cover. Display configuration and threshold values for color changes can be parameterized via Thermokon USEapp. The mounting base (included in delivery) allows mounting on a level surface or mounting on DIN rail TS35 (35x7,5 mm) according to EN 60715.

» TYPES AVAILABLE

Differential pressure and volume flow transducer optional with display – RS485 BACnet MS/TP

DPA250+ (LCD) RS485 BACnet MultiRange <AZ>
DPA2500+ (LCD) RS485 BACnet MultiRange <AZ>
DPA7000+ (LCD) RS485 BACnet MultiRange <AZ>

Differential pressure and volume flow transducer optional with display and 2 digital inputs – RS485 BACnet MS/TP

DPA2500+ (LCD) RS485 BACnet MultiRange <AZ> 2IN

MultiRange: Measuring ranges adjustable at the transducer
<AZ>: automatic zero-point calibration (optional)

» PRODUCT TESTING AND CERTIFICATION



Declaration of conformity

The declaration of conformity of the products can be found on our website <https://www.thermokon.de/>.

» SECURITY ADVICE – CAUTION



The installation and assembly of electrical equipment should only be performed by authorized personnel.

The product should only be used for the intended application. Unauthorised modifications are prohibited! The product must not be used in relation with any equipment that in case of a failure may threaten, directly or indirectly, human health or life or result in danger to human beings, animals or assets. Ensure all power is disconnected before installing. Do not connect to live/operating equipment.

Please comply with

- Local laws, health & safety regulations, technical standards and regulations
- Condition of the device at the time of installation, to ensure safe installation
- This data sheet and installation manual

» NOTES ON DISPOSAL



As a component of a large-scale fixed installation, Thermokon products are intended to be used permanently as part of a building or a structure at a pre-defined and dedicated location, hence the Waste Electrical and Electronic Act (WEEE) is not applicable. However, most of the products may contain valuable materials that should be recycled and not disposed of as domestic waste. Please note the relevant regulations for local disposal.

» TECHNICAL DATA

| | | | |
|---|--|---|--|
| Measuring values | differential pressure, volume flow | | |
| Medium | air or other non-flammable/non-aggressive gases | | |
| Output voltage | 0..10 V or 0..5 V, min. load 10 kΩ, (live-zero Konfiguration über Thermokon USEapp) | | |
| Network technology | RS485 BACnet MS/TP | | |
| Power supply | 15..35 V = or 19..29 V ~ | | |
| Power consumption | max. 2,3 W (24 V =) max. 4,3 VA (24 V ~) | | |
| Measuring range velocity | 0... 750.000 m³/h (default), optionally configurable via Thermokon USEapp | | |
| Measuring range pressure *selectable at the device | type 250 0..+25 0..+50 0..+100 0..+250 -25..+25 -50..+50 - 100..+100 -150..+150 Pa | type 2500 -100..+100 0..+100 0..+250 0..+500 0..+1000 0..+1500 0..+2000 0..+2500 Pa | type 7000 0..+1000 0..+1500 0..+2000 0..+2500 0..+3000 0..+4000 0..+5000 0..+7000 Pa |
| Accuracy pressure *deviation from calibration reference device (calibrator) | ±1 Pa at range <250 Pa | ±5 Pa at range <500 Pa, ±10 Pa at range >500 Pa | ±10 Pa at range <2000 Pa, ±25 Pa at range >2000 Pa |
| Max. working overpressure | 40 kPa | | |
| Calibration | manually, automatic zero-point calibration (optional) | | |
| Sensor | piezo measuring element | | |
| Inputs (optional) | 2IN 2x input for NTC10k or floating contact | | |
| Display (optional) | LCD 29x35 mm with RGB backlight units, pressure: Pa, inchWC, volume flow: m³/h, cfm (configurable) | | |
| Enclosure (type-dependent) | without LCD enclosure USE-L, PC, pure white, with removable cable entry | with LCD enclosure USE-L, PC, pure white, cover PC, transparent, with removable cable entry | |
| Protection | IP65 according to EN 60529 | | |
| Cable entry | M25, for wire max. Ø=7 mm, seal insert for fourfold cable entry | | |
| Connection electrical | Mainboard removable plug-in terminal, max. 2,5 mm² | Plug-in card removable plug-in terminal, max. 1,5 mm² | |
| Connection mechanical | pressure connection male Ø=5,0 mm / Ø=6,3 mm, connection tube: PVC, soft | | |
| Ambient condition | -10..+50 °C, max. 85% rH short term condensation | | |
| Mounting | screw mounted onto flat surface, prepared for mounting on DIN rail TS35 (35x7,5 mm) according to EN 60715 | | |

» **MOUNTING ADVICES**

Before installing the device, please check the leak tightness of the pressure lines. A prerequisite for the operation is a proper installation of all electrical supply, control and sensing leads as well as the pressurized connection line.

- In order to connect the device, the process lines must be unpressurized
- Consider the suitability of the device for the medium to be measured
- Consider maximum pressures

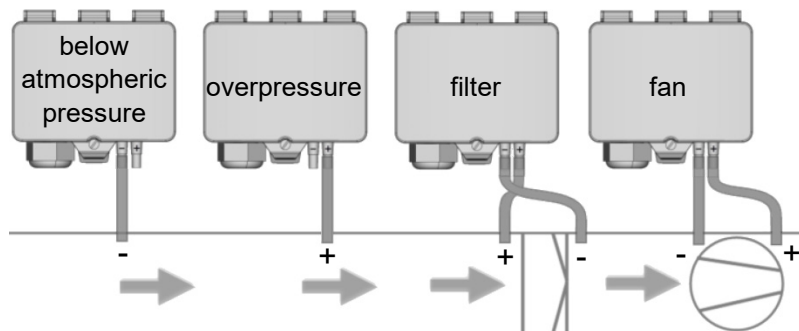

» **CONNECTION PLAN**

RS485 cable is looped through, connect both cable shields using the enclosed 2-pol. Connect terminal as shown.

DPA+ (LCD) RS485 BACnet MultiRange

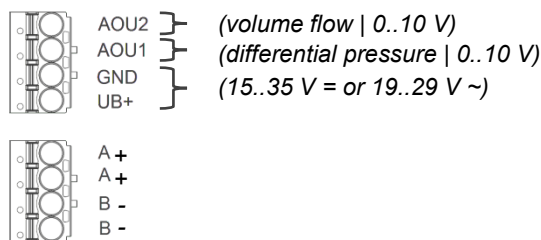
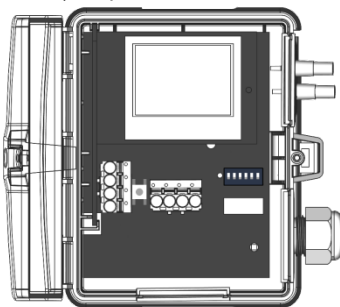

DPA+ (LCD) RS485 BACnet Multirange 2IN

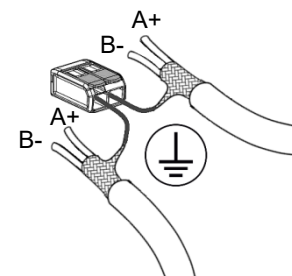
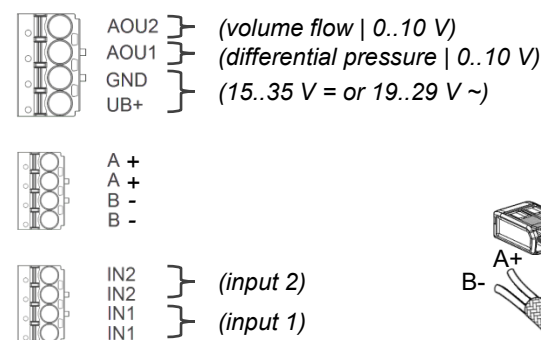
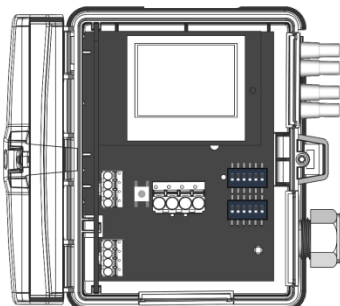

Measuring range adjustment – type 250 | 2500 | 7000

| | | | | | | | | |
|--------------------|--------------------|--------------------|--------------------|--------------------|--------------------|--------------------|--------------------|---|
| ON 1 2 3 | ON 1 2 3 | ON 1 2 3 | ON 1 2 3 | ON 1 2 3 | ON 1 2 3 | ON 1 2 3 | ON 1 2 3 | <input type="checkbox"/> = ON <input type="checkbox"/> = OFF |
| 0..+250 | 0..+100 | 0..+50 | 0..+25 | -25..+25 | -50..+50 | -100..+100 | -150..+150 | Pa |
| 0..+2500 | 0..+2000 | 0..+1500 | 0..+1000 | 0..+500 | 0..+250 | 0..+100 | -100..+100 | Pa |
| 0..+7000 | 0..+5000 | 0..+4000 | 0..+3000 | 0..+2500 | 0..+2000 | 0..+1500 | 0..+1000 | Pa |
| 0..+1 | 0..+0.4 | 0..+0.2 | 0..+0.1 | -0.1..+0.1 | -0.2..+0.2 | -0.4..+0.4 | -0.6..+0.6 | inchWC |
| 0..+10 | 0..+8 | 0..+6 | 0..+4 | 0..+2 | 0..+1 | 0..+0.4 | -0.4..+0.4 | inchWC |
| 0..+28 | 0..+20 | 0..+16 | 0..+12 | 0..+10 | 0..+8 | 0..+6 | 0..+4 | inchWC |

default

Response time

Output voltage

Unit

| | | | | | |
|----------------|----------------|----------------|----------------|----------------|----------------|
| ON 4 | ON 4 | ON 5 | ON 5 | ON 6 | ON 6 |
| 0,8 sec | 4,0 sec | 0..10 V | 0..5 V | Pa | inchWC |

default

default

default

The BACnet address of the device is set binary coded in the range of 1 ... 127 via 7 dip-switches. (the address 0 is reserved and cannot be selected).



BACnet Objects:

USE-RS485 BACnet interface

A detailed description of the BACnet interface can be found at the following link:

→ [Download](#)

Dip switches, plug-in card

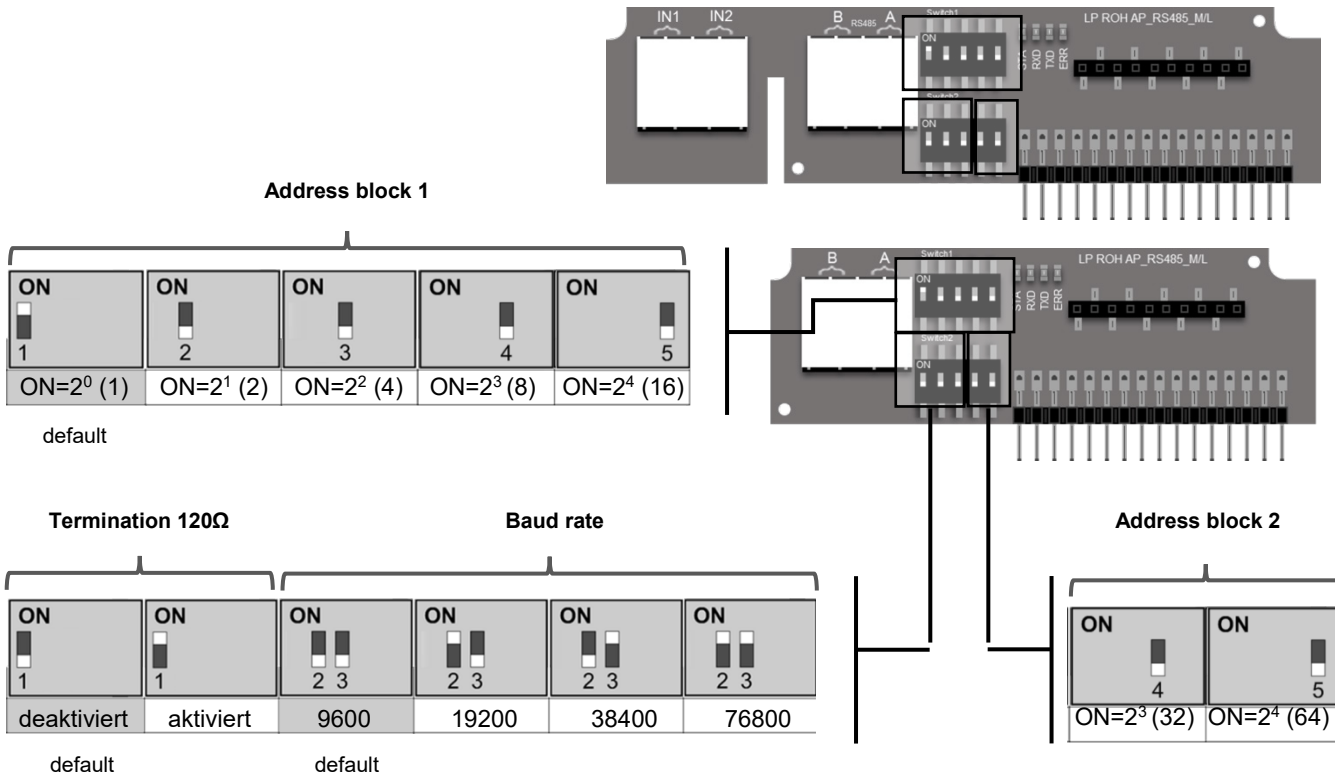

Flow calculation: (default parameters)

$$q = k * \sqrt{2 * \frac{\Delta p}{\rho}}$$

with k=1500, fan manufacturer Rosenberg, Comefri, Nicotra Gebhardt, default measuring range 0..750.000 m³/h.

Further calculation formulas, fan manufacturers and k-values can be selected via the USEapp.

| Rosenberg · Comefri · Gebhardt · Nicotra | Ziehl-Abegg · EBM-Papst | Fläkt Woods |
|--|---------------------------|-------------------------------------|
| $q = k * \sqrt{2 * \frac{\Delta p}{\rho}}$ | $q = k * \sqrt{\Delta p}$ | $q = \frac{1}{k} * \sqrt{\Delta p}$ |

» **AUTOMATIC ZERO-POINT CORRECTION - (OPTIONAL)**



Transmitters equipped with the auto-zero correction are maintenance free.

The auto-zero correction electronically adjusts the transmitter zero every 10 minutes. The function eliminates all output signal drift due to thermal, electronic or mechanical effects. The auto-zero correction takes approx. 4 seconds after which the device returns to its normal measuring mode. During the 4 second correction period, the output and display values will freeze to the latest measured value.

» **MANUAL ZERO-POINT CORRECTION (FOR DEVICES WITHOUT AUTO-ZERO FUNCTION)**

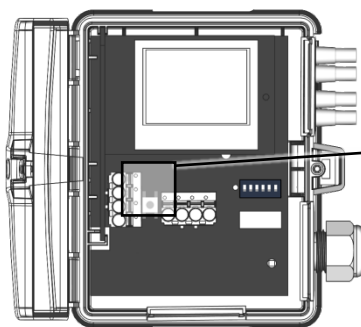

In normal operation zero point correction should be executed every 12 months.

Attention! For executing zero point correction the power supply must be connected one hour before.

- Release both connection tubes from the pressure terminals + and -
- Press the button until the LED lights permanently
- Wait until the LED flashes again and reinstall the connection tubes to the pressure ports (note + and -)

» **MEASURING VALUES (BACNET OBJECTS)**

| Objects | Access | Description | COV Increment | Unit |
|---------|--------|---------------------------------|------------------|------|
| AI-18 | R | Input 1 (Eingang Schaltkontakt) | 1 | |
| AI-19 | R | Input 2 (Eingang Schaltkontakt) | (nicht änderbar) | - |

Objekt AV-38=1 (Einheit SI)

| Objects | Access | Description | COV Increment | Unit |
|---------|--------|---|---------------|--------------|
| AI-8 | R | differential pressure | 0..7000 | Pa |
| AI-9 | R | volumetric flow (If Present Value is set to 2 in the AV-41 object, the value scales in the unit m³ / s) | 0..999.999 | m³/h m³/s |

| | | | | |
|-------|---|-----------------------------|------------------|----|
| AI-16 | R | Input 1 (Temperatur NTC10k) | 1.0 °C | °C |
| AI-17 | R | Input 2 (Temperatur NTC10k) | (nicht änderbar) | |

Objekt AV-38=2 (Einheit Imperial)

| Objects | Access | Description | COV Increment | Unit |
|---------|--------|-----------------------|---------------|------|
| AI-8 | R | differential pressure | 0..28 | inWC |
| AI-9 | R | volumetric flow | 0..999.999 | cfm |

| | | | | |
|-------|---|------------------------------|------------------|----|
| AI-16 | R | Input 1 (Temperature NTC10k) | 2.0 °F | °F |
| AI-17 | R | Input 2 (Temperature NTC10k) | (nicht änderbar) | |

» CONFIGURATION



The Thermokon bluetooth dongle with micro-USB is required for communication between USEapp and USE-M / USE L (Item No.: 668262). Commercial bluetooth dongles are not compatible.

Application-specific reconfiguration of the devices can be carried out using the Thermokon USEapp. The configuration is carried out in the voltage-supplied state.

The configuration-app and the app description can be found in the Google Play Store or in the Apple App Store.



» DIMENSIONS (MM)

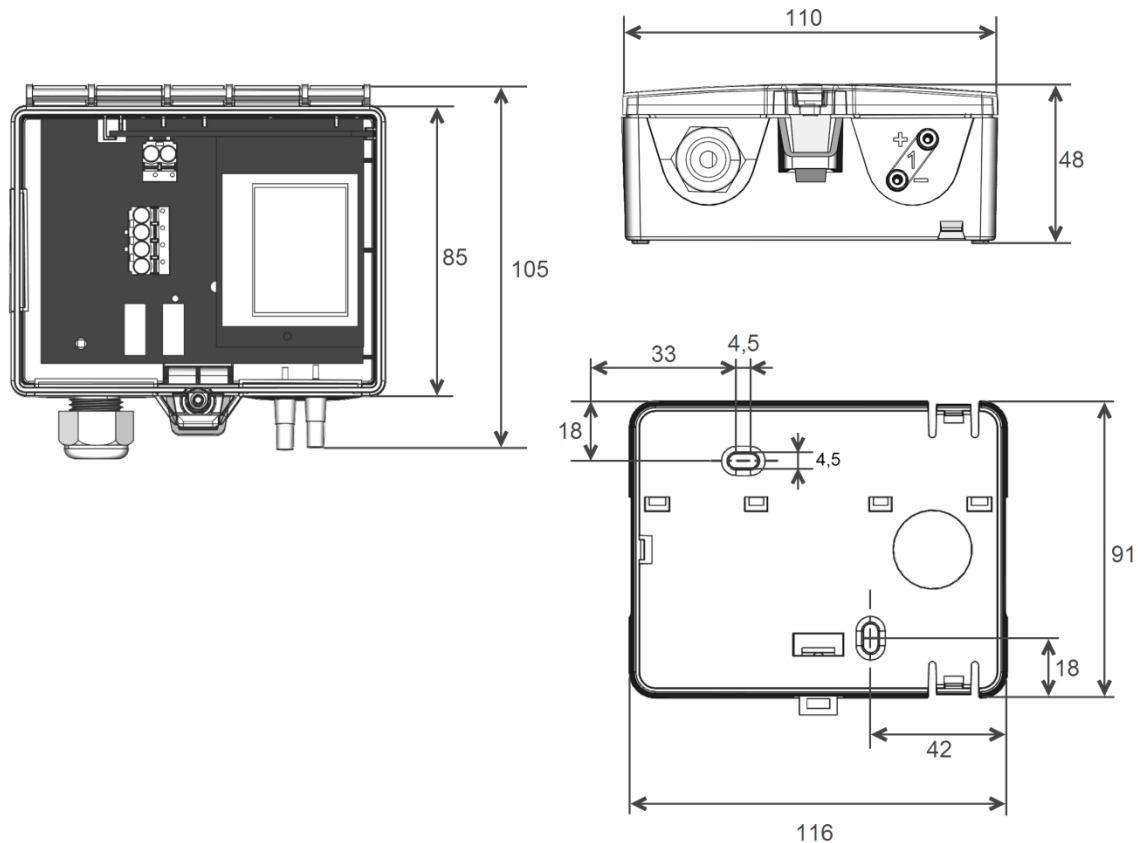

» ACCESSORIES (INCLUDED IN DELIVERY)

Mounting base enclosure USE-L

2 m PVC connection tube

KKS40 kit

• 2 plastic duct flanges • 4 mounting screws 4x20

Item No. 668361

Item No. 484268

Item No. 430135

Mounting kit universal

• Cover screw + screw cover • 2 Rawlplugs • 2 Screws (countersunk head) • 2 Screws (rounded head)

Item No. 698511

» ACCESSORIES (OPTIONAL)

Bluetooth dongle USE for USEapp

T-hose connector for pressure hoses $\varnothing=4$ mm (10 pcs)

Adapter 90° angle for pressure hoses $\varnothing=4$ mm

Metal duct connectors 40 mm

Metal duct connectors 100 mm

Item No. 668262

Item No. 668323

Item No. 668330

Item No. 265138

Item No. 302531