

# T7470A1009

## Space-Temperature Sensor

### PRODUCT DATA AND INSTALLATION INSTRUCTIONS

#### FEATURES

- Mountable directly on a wall.
- Operating range 43 to 104°F / 6 to 40°C.
- EAC- and CE-approved.
- IP 30 housing.
- Compact.



#### GENERAL

The T7470A1009 (available only in bulk packs, each containing five units) is equipped with a 20 kΩ NTC space-temperature sensor and can be directly wired to Honeywell controllers having an NTC 20 kΩ input.

Please refer to the technical specifications of the individual controllers in order to determine their suitability for use in conjunction with a given sensor application.

#### SENSOR CHARACTERISTIC

The 20 kΩ NTC temperature sensor follows a specific temperature-resistance curve (see Fig. 1).

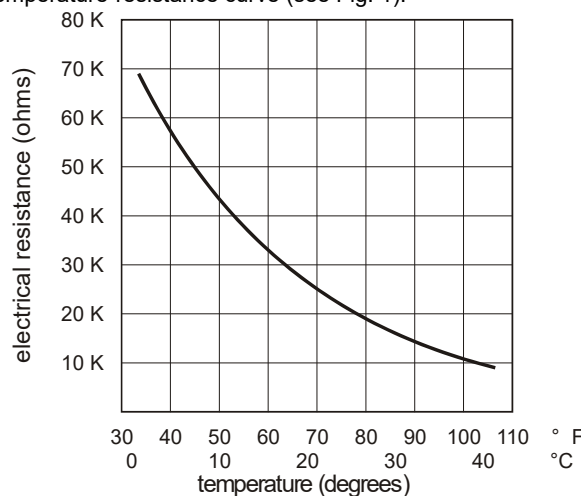

Fig. 1. Temperature vs. resistance for 20 kΩ sensor

## SPECIFICATIONS

**Dimensions (H × W × D):** 2 × 1-9/16 × 3/4 in.  
(56 × 46 × 19.3 mm).

**Construction:** Two-piece construction (a cover and an internally wired sub-base). Field wiring 16 to 22 AWG (1.5 to 0.34 mm<sup>2</sup>) connects to a terminal block.

**Operating Temperature:** 43...104°F / 6...40°C.

**Shipping Temperature:** -40...150°F / -40...65°C.

**Relative Humidity:** 5% to 95% non-condensing.

**Accuracy:**  $\Delta t = 0.3 \text{ K} + 1\% \cdot |t - 25 \text{ }^\circ\text{C}|$  (t in °C)

**Safety:** terminal box

**Protection standard:** IP30

**Approvals:** CE, EAC

## BEFORE MOUNTING

All wiring must comply with local electrical codes and ordinances or as specified on installation wiring diagrams.

### Removing the Cover

The cover of the space-temperature sensor can be easily popped off by applying pressure simultaneous pressure to the right and left sides at the top and bottom (see Fig. 2).

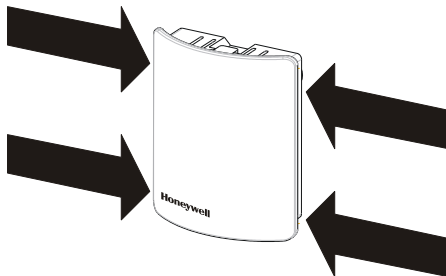

Fig. 2. Removing the cover

Space-temperature sensor wiring can be sized from 16 to 22 AWG (1.5 to 0.34 mm<sup>2</sup>), depending on the application. The maximum length of wire from a device to the space-temperature sensor is 1000 ft (305 m). Twisted-pair wire is recommended for wire runs longer than 100 ft (30.5 m).

### Wire Insertion

After removing the cover, the wires can be easily inserted into the terminal block as shown in Fig. 3. The terminals are insensitive to polarity.

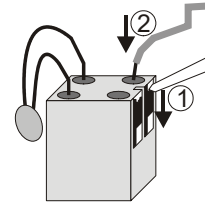

Fig. 3. Wire insertion

To facilitate wire insertion, it is possible to temporarily remove the terminal block from the housing. After wire insertion, however, the terminal block should be snapped back into place.

## MOUNTING

Mount the T7470A1009 on an inside wall approx. 54 in. (1.3 m) from the floor (or in the specified location) to allow exposure to the average zone temperature.

Maintain a mounting clearance of approx. 4 in. (10 cm) to both sides of the space-temperature sensor in order to allow free airflow.

Do not mount the space-temperature sensor on an outside wall, on a wall containing water pipes, or near air ducts. Avoid locations exposed to discharge air from registers or radiation from lights, appliances, or the sun.

Keep wiring at least one ft (305 mm) away from large inductive loads such as motors, line starters, lighting ballasts, and large power distribution panels. Run space-temperature sensor wiring separately from 50 Vac or greater power wiring.

The T7470A1009 can be mounted directly onto walls (see Fig. 4 for dimensions and drilling template), in which case the type of screws appropriate to the wall material should be used.

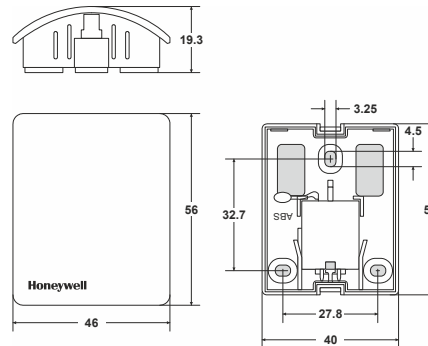

Fig. 4. T7470A1009 dimensions (in mm)

**Honeywell**  
THE POWER OF CONNECTED

Manufactured for and on behalf of the Connected Building Division of Honeywell Products and Solutions SARL, Z.A. La Pièce, 16, 1180 Rolle, Switzerland by its Authorized Representative:

### Home and Building Technologies

Honeywell GmbH  
Böblinger Strasse 17  
71101 Schönaich, Germany  
Phone +49 (0) 7031 637 01  
Fax +49 (0) 7031 637 740  
<http://ecc.emea.honeywell.com>

EN0B-0469GE51 R1118

Subject to change without notice