

VSxF-2/-3/-4

SMALL LINEAR VALVES PN16 FOR MODULATING AND ON/OFF-CONTROL

PRODUCT DATA



VSxF-2

VSxF-3

VSxF-4

GENERAL

These small linear valves are used in combination with small electric linear valve actuators and thermoelectric actuators for the control of hot and/or chilled water for fan coil units and small reheaters/recoolers in electric/electronic temperature control systems.

FEATURES

- Small size allows installation where space is limited
- Long stroke results in a high quality characteristic
- Soft seat provides low leakage rate and high rangeability
- High close-off pressure
- Wide standardized range of k_{vs} values
- Reduced k_{vs} values in the bypass to facilitate hydronic balancing
- Dezincification-resistant yellow brass
- Range of fittings available for different connections (soldered, threaded)
- Standardized opening direction across the complete VS portfolio (valve stem down to open A-B / A-AB)
- Valve diverting usage capability (depending on model)

SPECIFICATIONS

Models	Two-way VSxF-2 Three-way VSxF-3 Three-way with bypass VSxF-4
Operation	Two-way: spring-loaded, stem up to close port A to B; Three-way: spring-loaded, stem up to close port A to AB
Nominal pressure rating	PN16
Capacity index (k_{vs})	see tables on pages 2 and 3
Close-off pressures	see tables on pages 2 and 3
Leakage rate	$\leq 0.02\%$ of k_{vs}
Port connection	flat sealing connections in standard sizes

Valve body

Material	Brass
Size	DN15 (1/2"), DN20 (3/4"), DN25 (1-1/4")

Trim

Stem	Stainless steel
Plug	Brass
Suitable medium	Water, with max. 50% glycol
Controlled water temp.	2...120 °C

Modulating valves

VSMF-xxx	
Stroke	6.5 mm
Dimensions	see Fig. 4, Fig. 5, and Fig. 6
Characteristic	2-way: modified equal % 3-way: A-AB modified equal %; B-AB linear

ON/OFF valves

VSOFF-xxx	
Stroke	2.5 mm
Dimensions	see Fig. 4, Fig. 5, and Fig. 6

NAMING KEY

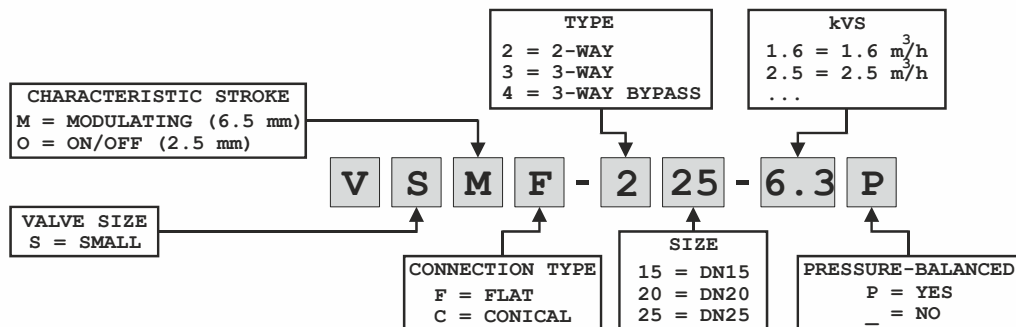

FLOW CAPACITIES AND CLOSE-OFF PRESSURE RATINGS

VSx F-2 Two-Way Valves with Flat Sealing

DN	k _{vs} A-B	type	stroke	order no.	close-off pressure with actuator		
					M6410C,L; M7410C,E (180 N)	MT8; M5410C1,L1 (90 N)	MT4;M7410A (90 N)
15	0.16	MOD	6.5	VSMF-215-0.16	600 kPa	600 kPa	--
15	0.25	MOD	6.5	VSMF-215-0.25	600 kPa	600 kPa	--
15	0.40	MOD	6.5	VSMF-215-0.4	600 kPa	600 kPa	--
15	0.63	MOD	6.5	VSMF-215-0.63	600 kPa	600 kPa	--
15	1.0	MOD	6.5	VSMF-215-1.0	600 kPa	600 kPa	--
15	1.6	MOD	6.5	VSMF-215-1.6	300 kPa	300 kPa	--
15	2.5	MOD	6.5	VSMF-215-2.5	100 kPa	100 kPa	--
20	2.5	MOD	6.5	VSMF-220-2.5	150 kPa	150 kPa	--
20	4.0	MOD	6.5	VSMF-220-4.0	50 kPa	50 kPa	--
25	6.3	MOD	6.5	VSMF-225-6.3P	250 kPa	250 kPa	--
25	8.0	MOD	6.5	VSMF-225-8.0P	250 kPa	250 kPa	--
15	1.0	ON-OFF	2.5	VSO F-215-1.0	600 kPa	600 kPa	600 kPa
15	1.6	ON-OFF	2.5	VSO F-215-1.6	300 kPa	300 kPa	300 kPa
15	2.5	ON-OFF	2.5	VSO F-215-2.5	150 kPa	150 kPa	150 kPa
20	2.5	ON-OFF	2.5	VSO F-220-2.5	200 kPa	200 kPa	200 kPa
20	4.0	ON-OFF	2.5	VSO F-220-4.0	100 kPa	100 kPa	100 kPa
25	4.0	ON-OFF	2.5	VSO F-225-4.0P	200 kPa	200 kPa	200 kPa
25	5.5	ON-OFF	2.5	VSO F-225-5.5P	200 kPa	200 kPa	200 kPa

VSxF-3 Three-Way Valves with Flat Sealing

DN	K _{vs}		type	stroke	applic.	order no.	close-off pressure with actuator		
	A-AB	B-AB					M6410C,L; M7410C,E (180 N)	MT8; M5410C1,L1 (90 N)	MT4;M7410A (90 N)
15	0.25	0.16	MOD	6.5	MIX	VSMF-315-0.25	600 kPa	600 kPa	--
15	0.40	0.25	MOD	6.5	MIX	VSMF-315-0.4	600 kPa	600 kPa	--
15	0.63	0.40	MOD	6.5	MIX	VSMF-315-0.63	600 kPa	600 kPa	--
15	1.0	0.63	MOD	6.5	MIX	VSMF-315-1.0	600 kPa	600 kPa	--
15	1.6	1.0	MOD	6.5	MIX	VSMF-315-1.6	300 kPa	300 kPa	--
15	2.5	1.6	MOD	6.5	MIX	VSMF-315-2.5	100 kPa	100 kPa	--
20	2.5	1.6	MOD	6.5	MIX	VSMF-320-2.5	150 kPa	150 kPa	--
20	4.0	2.5	MOD	6.5	MIX	VSMF-320-4.0	50 kPa	50 kPa	--
25	6.3	4.0	MOD	6.5	MIX	VSMF-325-6.3P	250 kPa	250 kPa	--
25	8.0	5.5	MOD	6.5	MIX	VSMF-325-8.0P	250 kPa	250 kPa	--
15	1.0	0.63	ON-OFF	2.5	MIX/DIV	VSOFF-315-1.0	600 / 200 kPa	600 / 200 kPa	600 / 200 kPa
15	1.6	1.0	ON-OFF	2.5	MIX/DIV	VSOFF-315-1.6	300 / 200 kPa	300 / 200 kPa	300 / 200 kPa
15	2.5	1.6	ON-OFF	2.5	MIX	VSOFF-315-2.5	150 kPa	150 kPa	150 kPa
20	2.5	1.6	ON-OFF	2.5	MIX	VSOFF-320-2.5	200 kPa	200 kPa	200 kPa
20	4.0	2.5	ON-OFF	2.5	MIX	VSOFF-320-4.0	100 kPa	100 kPa	100 kPa
25	4.0	2.5	ON-OFF	2.5	MIX	VSOFF-325-4.0P	200 kPa	200 kPa	200 kPa
25	5.5	3.5	ON-OFF	2.5	MIX	VSOFF-325-5.5P	200 kPa	200 kPa	200 kPa

VSxF-4 Four-Way Valves with Flat Sealing

DN	K _{vs}		type	stroke	applic.	order no.	close-off pressure with actuator		
	A-AB	B-AB					M6410C,L; M7410C,E (180 N)	MT8; M5410C1,L1 (90 N)	MT4;M7410A (90 N)
15	0.25	0.16	MOD	6.5	MIX	VSMF-415-0.25	600 kPa	600 kPa	--
15	0.40	0.25	MOD	6.5	MIX	VSMF-415-0.4	600 kPa	600 kPa	--
15	0.63	0.40	MOD	6.5	MIX	VSMF-415-0.63	600 kPa	600 kPa	--
15	1.0	0.63	MOD	6.5	MIX	VSMF-415-1.0	600 kPa	600 kPa	--
15	1.6	1.0	MOD	6.5	MIX	VSMF-415-1.6	300 kPa	300 kPa	--
15	2.5	1.6	MOD	6.5	MIX	VSMF-415-2.5	100 kPa	100 kPa	--
20	2.5	1.6	MOD	6.5	MIX	VSMF-420-2.5	150 kPa	150 kPa	--
20	4.0	2.5	MOD	6.5	MIX	VSMF-420-4.0	50 kPa	50 kPa	--
25	6.3	4.0	MOD	6.5	MIX	VSMF-425-6.3P	250 kPa	250 kPa	--
25	8.0	5.5	MOD	6.5	MIX	VSMF-425-8.0P	250 kPa	250 kPa	--
15	1.0	0.63	ON-OFF	2.5	MIX/DIV	VSOFF-415-1.0	600 / 200 kPa	600 / 200 kPa	600 / 200 kPa
15	1.6	1.0	ON-OFF	2.5	MIX/DIV	VSOFF-415-1.6	300 / 200 kPa	300 / 200 kPa	300 / 200 kPa
15	2.5	1.6	ON-OFF	2.5	MIX	VSOFF-415-2.5	150 kPa	150 kPa	150 kPa
20	2.5	1.6	ON-OFF	2.5	MIX	VSOFF-420-2.5	200 kPa	200 kPa	200 kPa
20	4.0	2.5	ON-OFF	2.5	MIX	VSOFF-420-4.0	100 kPa	100 kPa	100 kPa
25	4.0	2.5	ON-OFF	2.5	MIX	VSOFF-425-4.0P	200 kPa	200 kPa	200 kPa
25	5.5	3.5	ON-OFF	2.5	MIX	VSOFF-425-5.5P	200 kPa	200 kPa	200 kPa

OPERATION

The valves are supplied with a screwed-on adjustment cap for manual operation and for protection of the stem. If it should become necessary to flush the system, the valve can be opened between approx. 50% and 75% of the rated k_{vs} with the protection cap attached or fully opened via a connected actuator.

Typical Operation

All types of valves should be mounted in the return flow. If the Δp -values exceed 300 kPa, attention should be paid to the development of noise.

Two-Way Valves

Direction of flow always from port A to port B.

The built-in spring exerts a closing force on the A-B ports.

Port B: Outlet

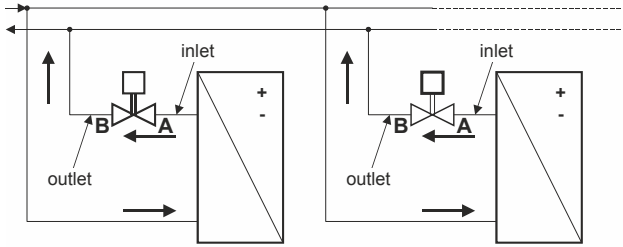

Fig. 1. Two-way valve operation

Three-Way Valves

The built-in spring exerts a closing force on the A-AB ports.

These valves are preferably used as mixing valves, this means:

Port AB: Total flow outlet

Port A: Controlled flow inlet

Port B: Bypass inlet

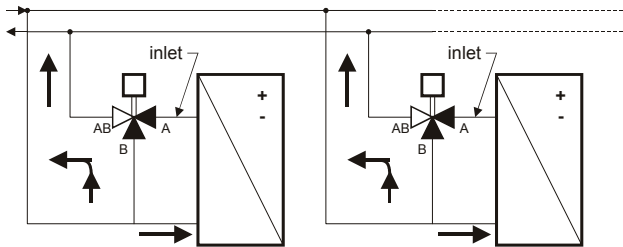

Fig. 2. Three-way valve operation

Three-Way Valves with Bypass

These valves simplify the installation, depends on the layout of the pipework, as the bypass pipe is part of the valve. The information for the normal three-way valves is also valid for this type.

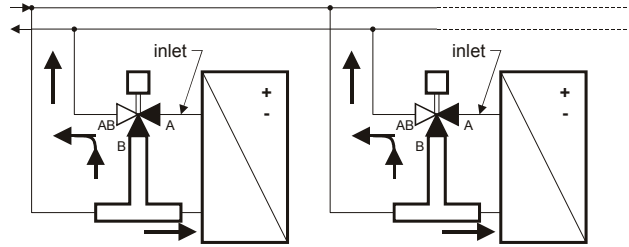

Fig. 3. Three-way valve with bypass

MOUNTING

When installing the valve care must be taken that the flow direction is correct (see section "Typical Operation"). The valve must not be mounted with the stem pointing downward.

The adjustment cap must be removed from the valve only when the actuator is fitted. The valve should be installed as stress-free as possible with a tightening torque of 25 to 30 Nm.

The valve is supplied complete with mounting instructions. The water quality must meet VDI 2035 requirements.

NOTE: Mount the actuator by hand, only. Do not use a tool, as this could result in damage.

MAINTENANCE / SPARE PARTS

The valves do not require any maintenance.

In case of failure or leakage, the valve must be replaced. No spare parts for the valve or sealing are available.

DISPOSAL

Statutory regulations and/or environmental protection considerations may require special handling in disposing of the valves.

ACCESSORIES

Valves VSxF-2 need two connection sets, valves VSxF-3 need three connection sets, and valves VSxF-4 need four connection sets.

connection	pipe size	DN	order number	connection set		description
Soldering	12 mm	15	AC-15FS			Consisting of 1 union nut, 1 solder bush, and 1 gasket
	15 mm	20	AC-20FS			
External Thread	R3/8"	15	AC-15FT			Consisting of 1 union nut, 1 tailpiece, and 1 gasket
	R1/2"	20	AC-20FT			
	R1"	25	ACS-25T			

dimensions of connection sets				order number
	a	c	d	
	G1/2"	12 mm		AC-15FS
	G3/4"	15 mm		AC-20FS
	G1/2"		R3/8"	AC-15FT
	G3/4"		R1/2"	AC-20FT
	G1-1/4"		R1"	ACS-25T

DIMENSIONS

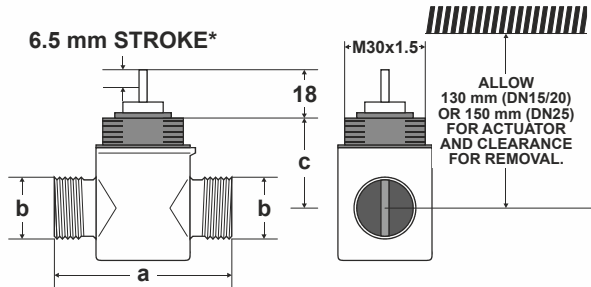

Fig. 4. Two-way valves, dimensions (mm)

***NOTE:** In the case of modulating valves, the stroke amounts to 6.5 mm, and the closure distance to 18 mm. In the case of ON/OFF valves, the stroke amounts to 2.5 mm, and the closure distance to 14 mm.

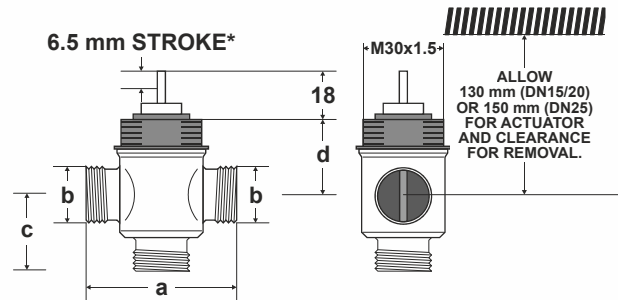

Fig. 5. Three-way valves, dimensions (mm)

***NOTE:** In the case of modulating valves, the stroke amounts to 6.5 mm, and the closure distance to 18 mm. In the case of ON/OFF valves, the stroke amounts to 2.5 mm, and the closure distance to 14 mm.

Table 1. Two-way valves, dimensions (mm)

	a	b	c
DN15	56	G 1/2 A	32
DN20	66	G 3/4 A	34
DN25	76	G1-1/4"	48

Table 2. Three-way valves, dimensions (mm)

	a	b	c	d
DN15	56	G 1/2 A	25.5	32
DN20	66	G 3/4 A	33	34
DN25	76	G1-1/4"	38	48

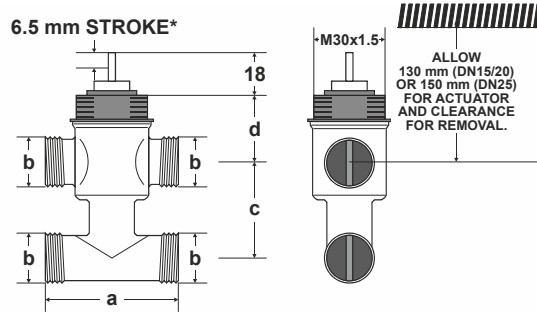

Fig. 6. Three-way valves with bypass, dimensions (mm)

*NOTE: In the case of modulating valves, the stroke amounts to 6.5 mm, and the closure distance to 18 mm. In the case of ON/OFF valves, the stroke amounts to 2.5 mm, and the closure distance to 14 mm.

Table 3. Three-way valves with bypass, dimensions (mm)

	a	b	c	d
DN15	56	G 1/2 A	40	32
DN20	66	G 3/4 A	40	34
DN25	76	G1-1/4"	62.5	48

DIMENSIONS WITH SNAP-ON

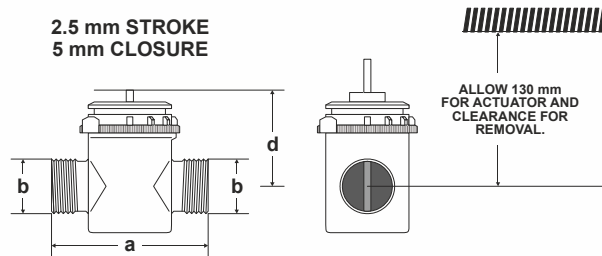

Fig. 7. Two-way valves with snap-on, dimensions (mm)

Table 4. Two-way valves with snap-on, dimensions (mm)

	A	B	D
DN15	56	G 1/2 A	34.5
DN20	66	G 3/4 A	36.6

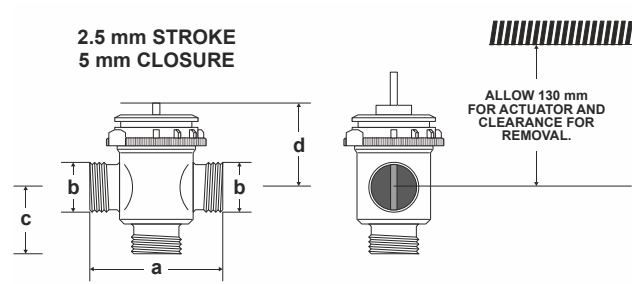

Fig. 8. Three-way valves with snap-on, dimensions (mm)

Table 5. Three-way valves with snap-on, dimensions (mm)

	A	B	C	D
DN15	56	G 1/2 A	24.5	34.5
DN20	66	G 3/4 A	33	36.6

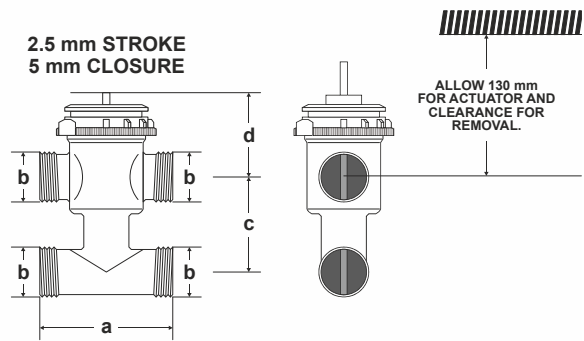

Fig. 9. Three-way valves with bypass and snap-on, dimensions (mm)

Table 6. Three-way valves with bypass, dimensions (mm)

	A	B	C	D
DN15	56	G 1/2 A	40	34.5
DN20	66	G 3/4 A	40	36.6

VALVE ACTION WITH MT-SERIES SMART-T THERMAL ACTUATORS

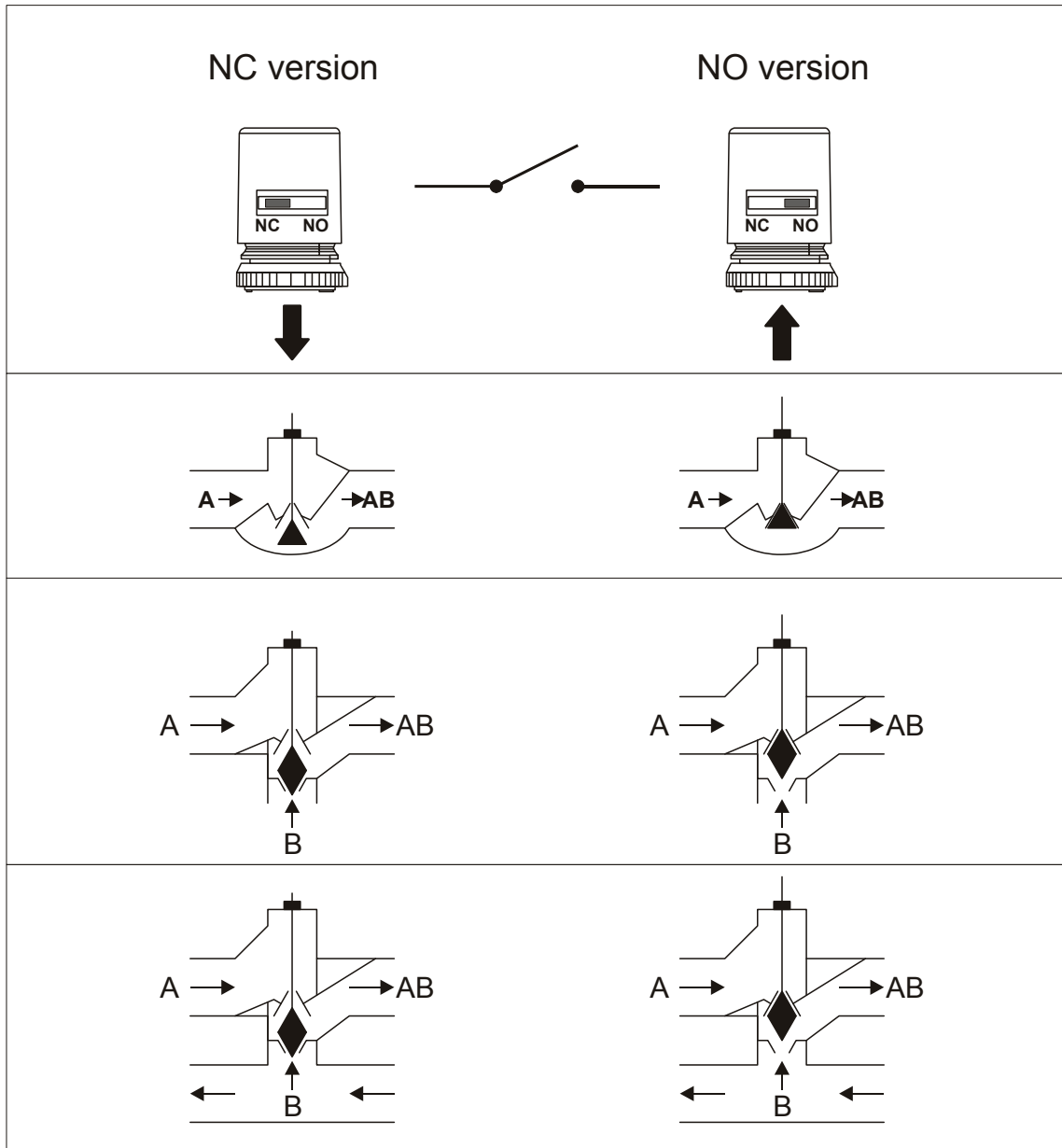

Fig. 10. Valve action with MT-series Smart-T Thermal Actuators

Home and Building Technologies

Honeywell GmbH
Böblinger Strasse 17
71101 Schönaich, Germany
Phone +49 (0) 7031 637 01
Fax +49 (0) 7031 637 740
<http://ecc.emea.honeywell.com>