

ML6435B

ELECTRIC LINEAR ACTUATOR FOR FLOATING CONTROL

SPECIFICATION DATA



GENERAL

The ML6435B actuator is designed to provide floating control together with the small linear valves V5832B/V5833A (DN25...DN40) and V5825B/V5872B for high-differential pressure.

These valve-actuator combinations are suitable especially for integration into compact or conventional stations for direct or indirect district heating connections, air handling units, and roof top units.

The V5825B or V5872B valve and ML6435B actuator combination provides safety close-off function and is approved according to DIN EN 14597.

FEATURES

- Easy and quick installation
- No separate linkage required
- No adjustments
- Low power consumption
- Force-limiting end switches
- Spring return
- Models for low and line voltage
- Synchronous motor
- Corrosion-resistant design
- Maintenance-free

SPECIFICATIONS

Temperature Limits

Ambient operating limits	0...+50 °C at 5 to 95% rh
Ambient storage limits	-40...+70 °C at 5 to 95% rh
Medium valve temperature	max. +130 °C

Safety

Protection standard	IP54 as per EN60529
Protection class	II as per EN60730-1
Operating mode	Type 2B as per EN 60730-1, 6.4

Wiring

Terminals	1.5 mm ²
Cable entry	PG13.5 with cut-out ring

Weight

0.5 kg

Dimensions

See Fig. 1 on page 3

Material

Cover	ABS-FR
Base	Glass fiber reinforced plastic

OS-number	ML6435B1008	ML6435B1016
supply voltage	24 Vac -15/+20%, 50/60 Hz	230 Vac +10/-15%, 50/60 Hz
power consumption	3 VA	6 VA
signal input 1	Supply voltage between terminals 1 and 24V~; actuator stem extends.	Supply voltage between terminals 1 and 230V~; actuator stem extends.
signal input 2	Supply voltage between terminals 2 and 24V~; actuator stem retracts.	Supply voltage between terminals 2 and 230V~; actuator stem retracts.
nominal stroke	6.5 mm	
run-time at 50 Hz	60 s	
nominal stem force	400 N	
spring return time (6.5 mm stroke)	max. 20 s	
spring return direction	Actuator stem retracts at power failure	

OPERATION

General

The drive of a synchronous motor is converted into linear motion of the actuator stem by using a spur gear transmission. Actuator and valve are directly connected by a nut.

An integrated mechanism limits the stem force.

Installed microswitches switch off the actuator precisely when the specified stem force is reached.

Manual Operation

The actuator is equipped with a manual operator (for 8 mm Hex Key). Manual operation is possible only after the power supply is switched off or disconnected. It disables the actuator safety function and should be used only for the purpose of checking the valve operation.

The manual operator is located under the cover.

Spring Return

The ML6435B spring return actuator provides a defined safety position of the valve in case of power failure. In the event of a power failure, the actuator retracts its stem.

Suitable Valves

	DN15	DN20	DN25	DN32	DN40	order no.
close-off pressure in kPa	1600	--	1600	--	--	V5872B
	-	--	1600	1200	1000	V5832B
	-	--	1600	1200	1000	V5833A
	2500	2500	2500	2500	--	V5825B

APPROVALS

NOTE: Actuators ML6435B1008 and ML6435B1016 in combination with the following valves are approved according to DIN EN 14597:

valve OS-no.	DIN registration no.
V5825B	1F152/08

DIMENSIONS

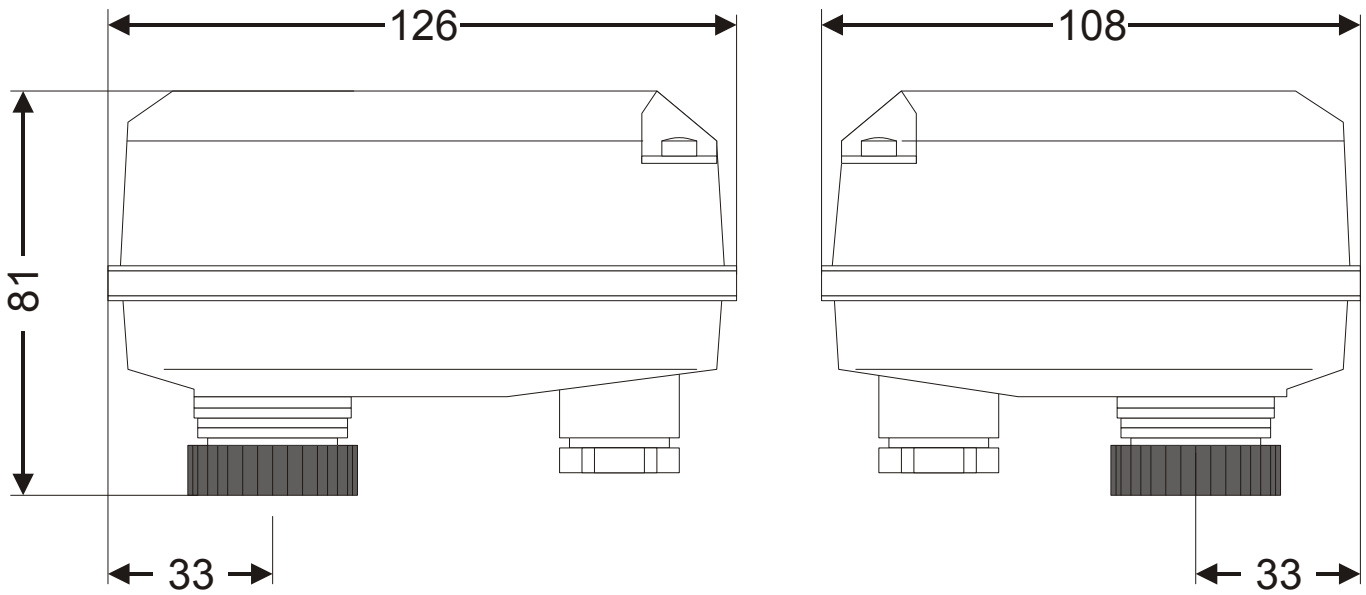

Fig. 1. Dimensions in mm

WIRING

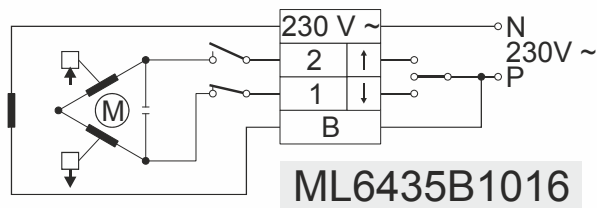
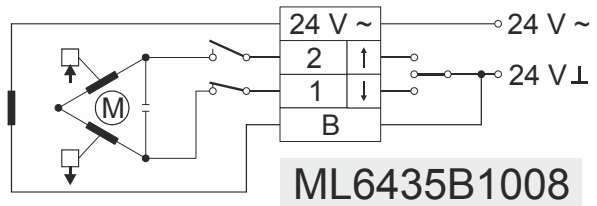

Fig. 2. Wiring

Honeywell

Manufactured for and on behalf of the Environmental and Combustion Controls Division of Honeywell Technologies Sàrl, Rolle, Z.A. La Pièce 16, Switzerland by its Authorized Representative:

Automation and Control Solutions

Honeywell GmbH
Böblinger Strasse 17
71101 Schönaich
Germany
Phone: (49) 7031 63701
Fax: (49) 7031 637493
<http://ecc.emea.honeywell.com>
Subject to change without notice.

EN0B-0259GE51 R0313