

6-way characterised control valves DN 15 / DN 20 / DN 25

Table of Contents

Introduction	2
Relevant information	2
Dimensions	2
Pipeline clearances	2
Water quality	2
Strainer	2
Water systems version	2
Structure of the 6-way characterised control valve	2
Range of use	2
Characteristic curve	3
Allocation of the sequences	3
Direction of flow	3
Marking of the connection gates	3
Motorisation	3
Design and dimensioning	4
Control characteristics	4
Design when using glycol	4
kvs values	4
Switching between sequences	4
Protection of the heating/cooling element (pressure release function)	5
Hydraulic circuits	6
Installation / commissioning / pressure testing / maintenance	7

Introduction

Relevant information	The data, information and limit values listed on the data sheet of the 6-way characterised control valve are to be taken into account and/or complied with, respectively.
Dimensions	The dimension of the valve-actuator combination used is dependent not only on the nominal diameter of the valve but also on the actuator used. The dimensions are listed in the R30...-B.. data sheet.
Pipeline clearances	The minimum clearances between the pipelines and the walls and ceilings required for project planning depend not only on the valve dimensions but also on the selected actuator. The dimensions can be found on the R30...-B.. data sheet.
Water quality	The water quality requirements specified in VDI 2035 must be adhered to.
Strainer	6-way characterised control valves are regulating devices. The use of central strainers in the system is recommended in order to prolong their service life for performing control tasks.
Water systems version	Application is permissible only in closed water circuits.

Structure of the 6-way characterised control valve

- 1 Connection flange
 - 2 Spindle
 - 3 Stem packing O-ring (EPDM)
 - 4 Closing element 1 with L-bore
 - 5 Closing element 2 with L-bore
 - 6 Valve seat (PTFE, O-ring EPDM)
 - 7 Characterised disc
 - 8 Supply sequence 1 connection *
 - 9 Return sequence 1 connection *
 - 10 Supply sequence 2 connection *
 - 11 Return sequence 2 connection *
 - 12 Supply heating/cooling element connection *
 - 13 Return heating/cooling element connection *
- * Internal thread according to ISO 7-1
 DN15: Rp 1/2", DN20: Rp 3/4", DN25: Rp 1"

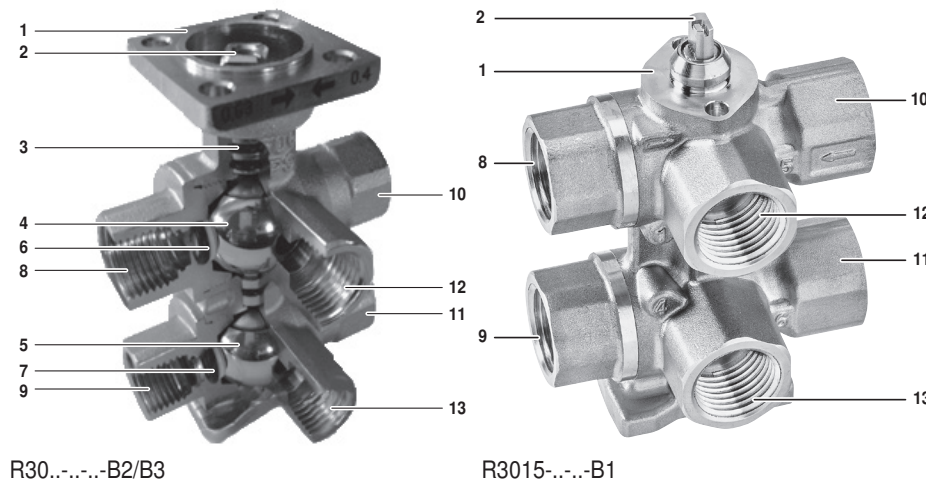

Range of use

The 6-way characterised control valve has been specially developed for use with combined heating and cooling elements. A 6-way characterised control valve performs the function of four 2-way valves or two 2-way valves and one changeover valve.

Picture legend

HC	Heating circuit
CC	Cooling circuit
HCE	Combined heating and cooling element

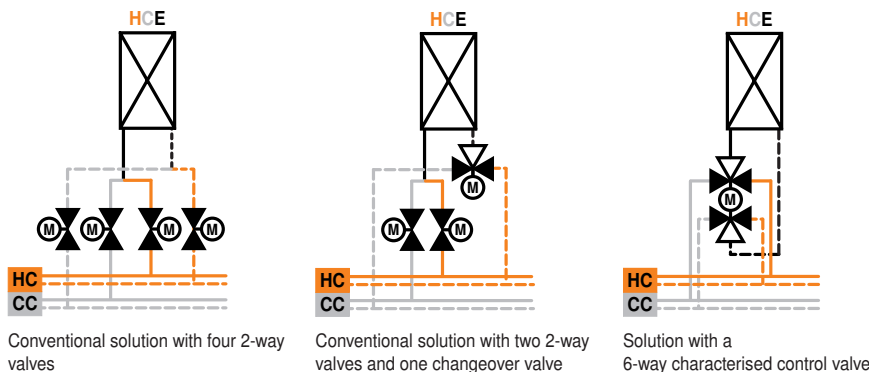

The 6-way characterised control valve handles control of hot and cold water.

Characteristic curve

When the valve is rotated by 90°, these 3 sequences are run through.

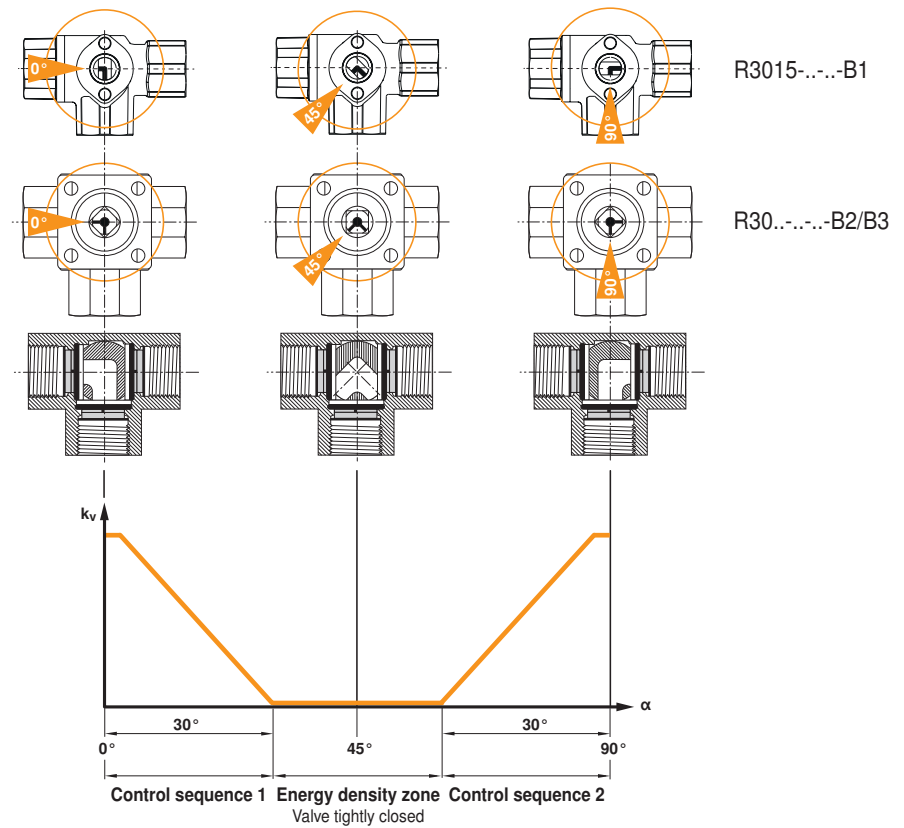

Allocation of the sequences

Allocation to hot and chilled water is in principle, freely selectable. However, due to installation safety, the definition of an equal allocation for all valves is recommended.



The following mandatory allocation is to be selected when the room temperature controller CRK24-B1 from Belimo is used, due to the control characteristics:
 Sequence 1 = cooling
 Sequence 2 = heating

Direction of flow

The direction of flow must be observed.

Sequence 1

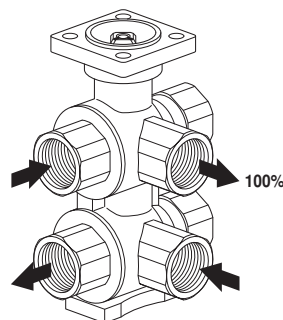

Sequence 2

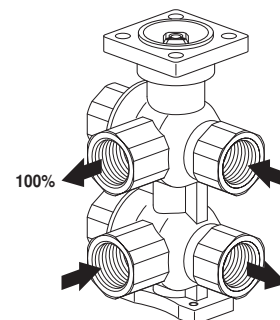

Marking of the connection gates

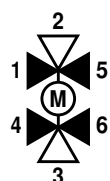

These are numbered from 1 to 6 for the purpose of secure allocation of the connections during planning and installation.

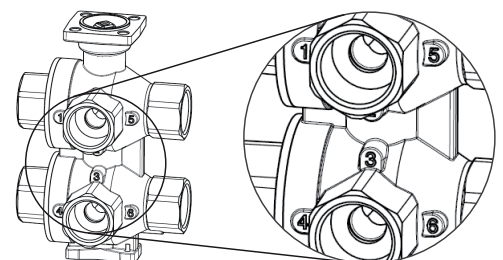

Motorisation

6-way characterised control valves are motorised with a rotary actuator. The control must be modulating.

Design and dimensioning

Control characteristics To ensure a valve attains good control characteristics thus a long service life for the control element, it needs to be correctly designed with the correct valve authority. The valve authority av is the benchmark for the control characteristics of the valve in combination with the hydraulic network. The valve authority is the relation between the differential pressure of the fully open valve at nominal flow and the maximum differential pressure for the closed valve. The higher the valve authority, the better the control characteristics. The smaller the valve authority av becomes, the more the operational behaviour of the valve will deviate from the linearity i.e.. the poorer the volumetric flow control will be. In practice the intended av is >0.5 .

Design when using glycol To reduce the freezing point of water, salt was added to the water in the past. These were called brine applications. Today glycol is used and we talk about cold agents. Depending on the concentration of the cold agent used (type of glycol) and the medium temperature, the density of the water/glycol mixture varies between 1 and 9 percent. The resultant volume deviation is less than the permissible volume tolerance of the valve's k_{VS} value (by ± 10 percent according to VDE 2178) and as a rule need not be taken into account even if glycol requires a slightly higher k_V value. Depending on the type of glycol, compatibility with the valve materials used must be guaranteed and the permissible maximum concentration (50 percent) must not be exceeded.

k_{VS} values Since different k_{VS} values are often required for heating and cooling, 6-way characterised control valves are available with different k_{VS} values for sequences 1 and 2. For a full overview, see data sheet R30...-...-B... .

Using an additional flow limiter When using additional flow limiting valves (e.g. PIQCV C2..QP(T)-.. with manual flow rate setting) or an additional pressure-independent control valve (e.g. motorised PIQCV) at the system level, it is not necessary to use the flow characterised disc in the 6-way valve in the system to reduce the k_{VS} value. The differential pressure required for operation is kept as low as possible in this manner. In addition, possible noise generation in conjunction with the additional components used is avoided.

DN15 max. k_{VS} 0.63 m ³ /h:	R3015-P63-P63-B1
DN15 max. k_{VS} 1.8 m ³ /h:	R3015-1P8-1P8-B2
DN20 max. k_{VS} 4 m ³ /h:	R3020-4-4-B2
DN25 max. k_{VS} 6.3 m ³ /h:	R3025-6P3-6P3-B3

Switching between sequences

As with all combined heating/cooling elements in 4-pipe systems, mass displacement can occur when using 6-way characterised control valves.

Mass displacement With each switch (from cooling to heating operation or from heating to cooling operation) water is displaced from one circuit to the other. Due to the different medium temperatures, the density of this water differs. Due to the constant volume in the heating/cooling element, the quantity of water displaced has a different mass. When switching from cooling to heating, more mass is shifted than when switching from heating to cooling. This mass displacement can lead to the cooling circuit being emptied. It is important to cater for this normal behaviour. For corresponding recommendations, see the chapter 'Hydraulic circuits'.

Media Due to the mass displacement that occurs, the medium in both circuits needs to have the same properties (glycol concentration).

Protection of the heating/cooling element (pressure release function)

In cases of combined heating/cooling elements, the medium is enclosed in the element when they are in closed status (no heating or cooling). The pressure of the enclosed medium can rise or fall due to changes in medium temperature caused by the ambient temperature. The 6-way characterised control valve have an integrated pressure release function for the purpose of compensating for such pressure changes.

Design for pressure release

The upper ball of the characterised control valve has a groove that forms a link between the 'Supply Sequence 1' (Gate 1) connection point and the heating/cooling element connected at Gate 2 when the valve is closed.

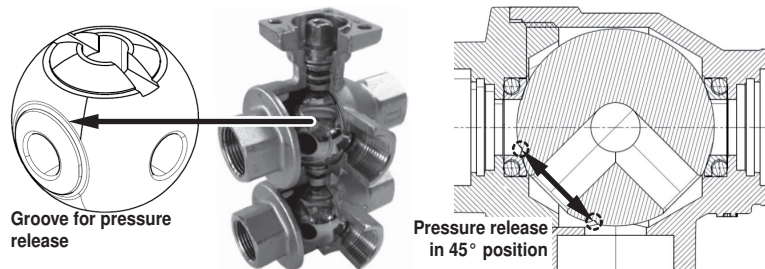

Function

Pressure change in the heating/cooling element with closed valve

The corresponding differential pressure in the heating/cooling element is compensated for by means of the connection to the 'Sequence 1' circuit. No further flow of water takes place after the pressure compensation due to the same absolute pressures in Sequence 1, in the heating and cooling element and in the lower closing element, which closes air-bubble tight.

Behaviour in hot or cold operation

The pressure relief function has no influence on the hot or cold operation. When operating sequence 1, the function is on the same side as the desired water flow. When operating sequence 2, the pressure relief function is not active. A direct mixing of water of the sequences of 1 and 2 is not possible duration operation.

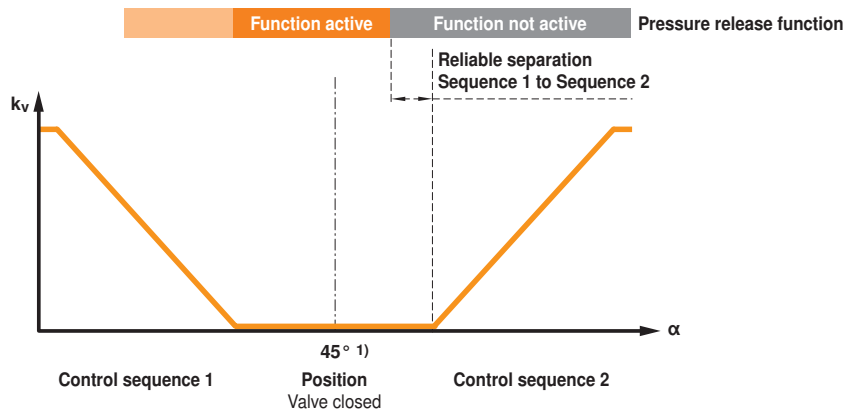

¹⁾ Positioning signal for closed position:
 Operating range drive 2...10 V: Y = 6 Volt
 Operating range drive 0.5...10 V: Y = 5.25 Volt

Valve leakage rate

Each water circuit is channeled through two valve cones (series circuit). As a result of the continued air-bubble tight closing of the lower closing element 2, the valve continues to exhibit Leakage rate A in accordance with EN 12266-1, even for Sequence 1.

Equivalent circuit diagram

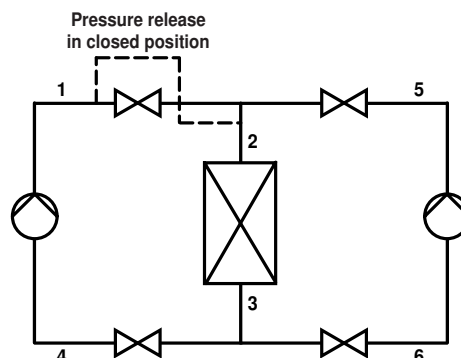

Hydraulic circuits

For correct operation, the following planning instructions need to be complied with, among others:

Media The medium in both circuits needs to have the same quality (glycol concentration).

System pressure The system pressures in the heating and cooling circuit must have the same value.

Possible hydraulic circuits In a 4-pipe system with heating and cooling circuits, the effect of mass displacement always exists regardless of the valve used (see chapter on mass displacement). To cater for this behaviour and prevent mass displacement, there are various solutions and corresponding precautionary measures.

1. Two expansion vessels

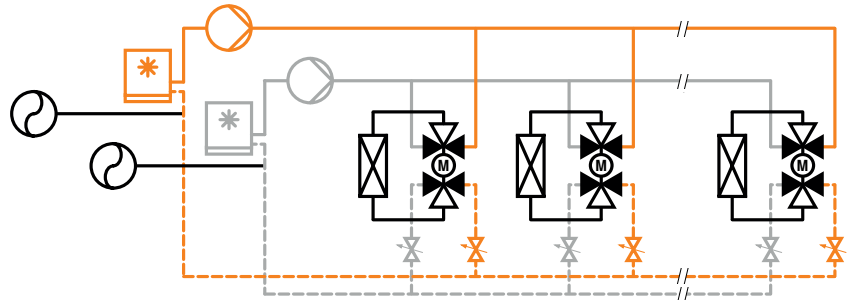

– The effect of mass displacement can be compensated for by refilling and emptying the circuit.

2. One expansion vessel

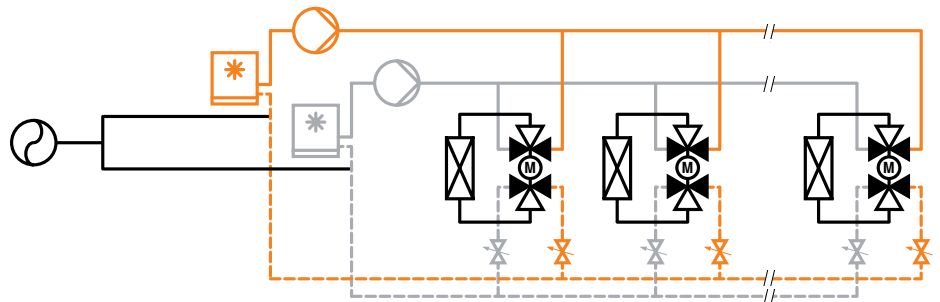

- One expansion vessel for both circuits. Connection point on the suction side of the pumps.
- Pumps at the same height.
- Connection line between heating circuit return and cooling circuit return.
- The same static pressure on the suction side of the pumps.

3. Two expansion vessels in a hydraulic coupling system

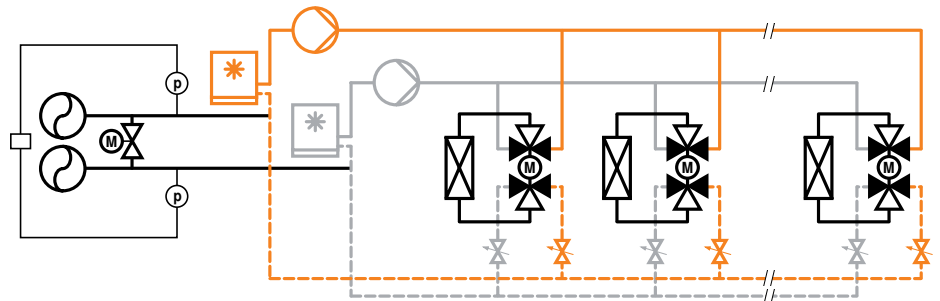

- The same static pressure on the suction side of the pumps.
- Pumps at the same height.
- The 2-way valve remains closed during operation.
- The 2-way valve will open if the pressures p_{Heating} and p_{Cooling} exhibit a certain difference due to the mass displacement.
- The system pressures are balanced.
- The 2-way valve is closed again after the compensation.

Installation/Commissioning/Pressure testing/Maintenance

Valve position The ball position can be discerned by means of the marking on the top of the spindle.

Valve delivery condition The valves are delivered ex works as shown with the picture below.

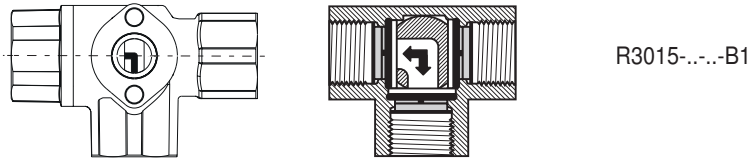

R3015-...-B1

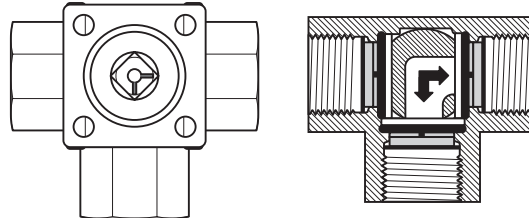

R30...-...-B2/B3

Delivery condition conforms to valve position 90°/positioning signal 10 V.

Delivery with valve installed For visualisation purposes, the actuator has two green dots.

Only valid for R30...-...-B2/B3

R3015-...-B1 cannot be supplied with the actuator installed ex works

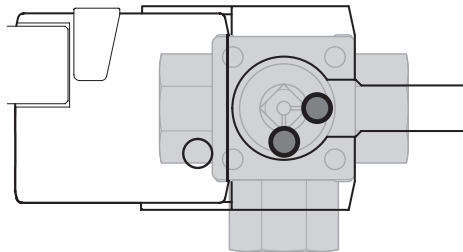

Pressure testing Due to the built-in pressure release safety function, the following needs to be observed:

Pressure testing with connected heating/cooling element

If the connected consumer circuit is also to be tested, pressure testing can be performed without additional restrictions in valve positions 'Sequence 1 open' (angle of rotation 0°) or 'Sequence 2 open' (angle of rotation 90°).

When tested in closed valve position (45°), note that the connected heating/cooling element is likewise pressurised with the pressure in sequence 1.

Pressure testing without connected heating/cooling element

In valve closed position (45°) the sequence 1 test medium flows via gates 1 and 2. This behaviour does not constitute a malfunction since the valve closes both water circuits reliably due to the air-bubble tightness of the second closing element during operation.

Possibilities:

- Individual testing of water circuits
 1. Sequence 1 test with valve in 90° position
Note: Prior to switching, sequence 1 needs to be emptied.
 2. Sequence 2 test with valve in 0° position

or

- Additional isolation of gate 2

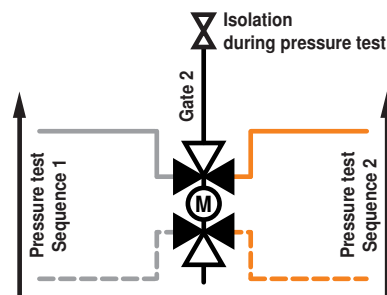

Maintenance 6-way characterised control valves are maintenance-free.

All inclusive.



5-year guarantee



On site around the globe



Complete product range from a single source



Tested quality



Short delivery times



Comprehensive Support

Switzerland

BELIMO Automation AG
Swiss Sales
Brunnenbachstrasse 1
CH-8340 Hinwil
Tel. +41 (0)43 843 62 12
Fax +41 (0)43 843 62 66
verkch@belimo.ch
www.belimo.ch