

Characterised control valve with sensor-operated flow rate or power control, power and energy-monitoring function, 3-way, Internal and external thread, PN 25 (Energy Valve)

- Nominal voltage AC/DC 24 V
- Control modulating, communicative, hybrid
- For closed cold and warm water systems
- For modulating control of air-handling and heating systems on the water side
- Ethernet 10/100 Mbit/s, TCP/IP, integrated web server
- Communication via BACnet, Modbus, Belimo MP-Bus or conventional control
- PoE (Power over Ethernet) Power supply possible
- Conversion of sensor signals

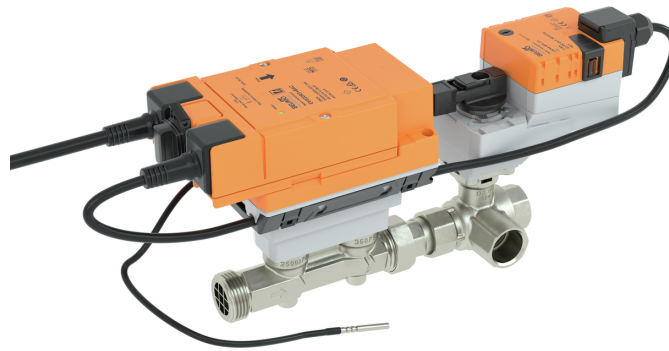

Type Overview

Type	DN	Rp ["]	G ["]	V'nom [l/s]	V'nom [l/min]	V'nom [m³/h]	kvs theor. [m³/h]	PN
EV015R3+BAC	15	1/2	3/4	0.42	25	1.5	2.8	25
EV020R3+BAC	20	3/4	1	0.69	41.7	2.5	4.8	25
EV025R3+BAC	25	1	1 1/4	0.97	58.3	3.5	8.1	25
EV032R3+BAC	32	1 1/4	1 1/2	1.67	100	6	11.4	25
EV040R3+BAC	40	1 1/2	2	2.78	166.7	10	17.1	25
EV050R3+BAC	50	2	2 1/2	4.17	250	15	25	25

kvs theor.: Theoretical kvs value for pressure drop calculation

Structure

Components The Belimo Energy Valve consists of a characterised control valve, an actuator and a thermal energy meter with a logic and a sensor module.

The logic module provides the power supply, the communication interface and the NFC connection of the energy meter. All relevant data are measured and recorded in the sensor module.

This modular design of the energy meter means that the logic module can remain in the system if the sensor module is replaced.

- External temperature sensor T1
- Integrated temperature sensor T2
- Logic module 1
- Sensor module 2
- Characterised control valve with actuator 3

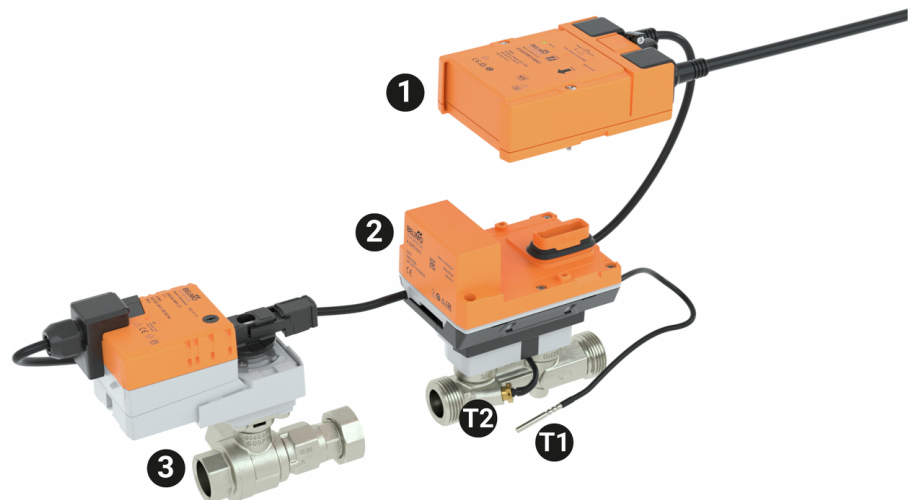

Technical data

Electrical data	
Nominal voltage	AC/DC 24 V
Nominal voltage frequency	50/60 Hz

Electrical data	Nominal voltage range	AC 19.2...28.8 V / DC 21.6...28.8 V	
	Power consumption in operation	4 W (DN 15, 20, 25) 5 W (DN 32, 40, 50)	
	Power consumption in rest position	3.7 W (DN 15, 20, 25) 3.9 W (DN 32, 40, 50)	
	Power consumption for wire sizing	6.5 VA (DN 15, 20, 25) 7.5 VA (DN 32, 40, 50)	
	Connection supply / control	Cable 1 m, 6 x 0.75 mm ²	
	Connection Ethernet	RJ45 socket	
	Power over Ethernet PoE	DC 37...57 V 11 W (PD13W) IEEE 802.3af / at Type 1, Class 3	
	Conductors, cables	24 AC/DC, cable length <100 m, no shielding or twisting required Shielded cables are recommended for supply via PoE	
	Data bus communication	Communicative control	BACnet IP, BACnet MS/TP Modbus TCP, Modbus RTU MP-Bus Cloud
		Number of nodes	BACnet / Modbus see interface description MP-Bus max. 8
Conductors, cables		24 AC/DC, cable length <100 m, no shielding or twisting required Shielded cables are recommended for supply via PoE	
Functional data	Operating range Y	2...10 V	
	Input Impedance	100 kΩ	
	Operating range Y variable	0.5...10 V	
	Position feedback U	2...10 V	
	Position feedback U note	Max. 1 mA	
	Position feedback U variable	0...10 V 0.5...10 V	
	Sound power level Motor	35 dB(A) (DN 15, 20, 25, 32) 45 dB(A) (DN 40, 50)	
	Adjustable flow rate V'max	25...100% of V'nom	
	Control accuracy	±5% (of 25...100% V'nom) @ Glycol 0% vol.	
	Control accuracy note	±10% (of 25...100% V'nom) @ Glycol 0...60% vol.	
	Min. controllable flow	1% of V'nom	
	Parametrisation	via NFC, Belimo Assistant App via integrated web server	
	Fluid	Cold and warm water, water with glycol up to max. 60% vol.	
	Fluid temperature	-10...120°C	
	Close-off pressure Δps	1400 kPa	
	Differential pressure Δpmax	350 kPa	
	Differential pressure note	200 kPa for low-noise operation	
	Flow characteristic	equal percentage, optimised in the opening range (switchable to linear)	
	Leakage rate	air-bubble tight, leakage rate A (EN 12266-1)	
	Installation position	upright to horizontal (in relation to the stem)	
Servicing	maintenance-free		
Manual override	with push-button, can be locked		
Measuring data	Measured values	Flow Temperature	

Measuring data	Temperature sensor T1 / T2	Pt1000 - EN60751, 2 conductor technology, inseparably connected Cable length external sensor T1: 3m
	<hr/>	
Flow measurement	Measuring principle	Ultrasonic volumetric flow measurement
	Measuring accuracy flow	±2% (of 25...100% V'nom) @ Glycol 0% vol.
	Measuring accuracy flow note	±6% (of 25...100% V'nom) @ Glycol 0...60% vol.
	Min. flow measurement	0.5% of V'nom
<hr/>		
Temperature measurement	Measuring accuracy absolute temperature	± 0.35°C @ 10°C (Pt1000 EN60751 Class B) ± 0.6°C @ 60°C (Pt1000 EN60751 Class B)
	Measuring accuracy temperature difference	±0.18 K @ ΔT = 10 K ±0.23 K @ ΔT = 20 K
	Resolution	0.05°C
<hr/>		
Glycol monitoring	Measurement display glycol	0...40% or >40%
	Measuring accuracy glycol monitoring	±4% (0...40%)
<hr/>		
Safety data	Protection class IEC/EN	III, Protective Extra-Low Voltage (PELV)
	Degree of protection IEC/EN	IP40
	Degree of protection note	IP54 when using protective cap or protective grommet for RJ45 socket
	Measuring Instruments Directive	CE according to 2014/32/EU
	Pressure equipment directive	CE according to 2014/68/EU
	EMC	CE according to 2014/30/EU
	Certification IEC/EN	IEC/EN 60730-1:11 and IEC/EN 60730-2-15:10
	Quality Standard	ISO 9001
	Mode of operation	Type 1
	Rated impulse voltage supply / control	0.8 kV
	Pollution degree	3
	Ambient temperature	-30...50°C
	Storage temperature	-40...80°C
	Ambient humidity	Max. 95% RH, non-condensing
<hr/>		
Materials	Valve body	Brass
	Flow measuring pipe	Brass body nickel-plated
	Closing element	Stainless steel
	Spindle	Stainless steel
	Spindle seal	EPDM O-ring
	Immersion sleeve	Brass
	T-Piece	Nickel-plated brass body

Safety notes

- This device has been designed for use in stationary heating, ventilation and air-conditioning systems and must not be used outside the specified field of application, especially in aircraft or in any other airborne means of transport.
- Outdoor application: only possible in case that no (sea) water, snow, ice, insulation or aggressive gases interfere directly with the device and that it is ensured that the ambient conditions remain within the thresholds according to the data sheet at any time.
- Only authorised specialists may carry out installation. All applicable legal or institutional installation regulations must be complied during installation.
- The connection between the control valve and the measuring tube should not be separated.
- The device contains electrical and electronic components and must not be disposed of as household refuse. All locally valid regulations and requirements must be observed.

Product features

Mode of operation	The HVAC performance device is comprised of four components: characterised control valve (CCV), measuring pipe with volumetric flow sensor, temperature sensors and the actuator itself. The adjusted maximum flow (V'max) is assigned to the maximum control signal DDC (typically 10 V / 100%). Alternatively, the control signal DDC can be assigned to the valve opening angle or to the power required on the heat exchanger (see power control). The HVAC performance device can be controlled via communicative or analogue signals. The fluid is detected by the sensor in the measuring pipe and is applied as the flow value. The measured value is balanced with the setpoint. The actuator corrects the deviation by changing the valve position. The angle of rotation α varies according to the differential pressure through the control element (see flow rate curves).
Calibration certificate	A calibration certificate is available in the Belimo Cloud for each thermal energy meter. If required, this can be downloaded as a PDF with the Belimo Assistant App or via the Belimo Cloud frontend.
Power calculation	The thermal energy meter calculates the current thermal power based on the current flow rate and the measured temperature difference.
Energy consumption	The energy consumption data can be read out as follows: <ul style="list-style-type: none"> - Bus - Cloud API - Belimo Cloud Account of the device owner - Belimo Assistant App - Integrated web server
PoE (Power over Ethernet)	If necessary, the thermal energy meter can be supplied with power via the Ethernet cable. This function can be enabled via the Belimo Assistant App or the web server. DC 24 V (max. 8 W) is available at wires 1 and 2 for power supply of external devices (e.g. actuator or active sensor). Caution: PoE may only be enabled if an external device is connected to wires 1 and 2 or if wires 1 and 2 are insulated!
Spare parts	Sensor module of the thermal energy meter consisting of: <ul style="list-style-type: none"> - 1 x sensor module including integrated temperature sensor T2 and external temperature sensor T1
3-way characterised control valve	3-way characterised control valves are mixing devices. The direction of flow must be observed in every load case. The installation in supply or return depends on the selected hydronic circuit. The 3-way characterised control valve must not be used as a diverting valve.

Hydronics The 3-way Belimo Energy Valve is intended for use in a system with low pressure manifolds.



This design results in approximately the same pressures in the flow and return manifold ($\Delta p_{VR1} \approx \Delta p_{VR2}$).

The valve is therefore used in a mixing circuit. The constant flow rate flowing through the consumer (heating/cooling coil) is determined by the internal pump. The 3-way Belimo Energy Valve only affects the mixing ratio flow rate/bypass. The valve position influences the amount of return water added to the flow via the bypass.

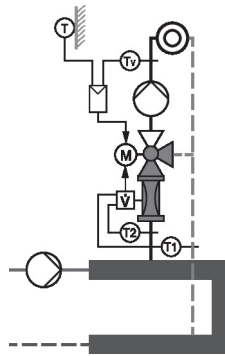

Flow rate curves

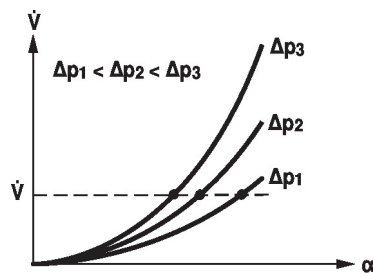

Transmission behaviour HE Heat exchanger transmission behaviour

Depending on the construction, temperature spread, fluid characteristics and hydronic circuit, the power Q is not proportional to the water volumetric flow V' (Curve 1). With the classical type of temperature control, an attempt is made to maintain the control signal Y proportional to the power Q (Curve 2). This is achieved by means of an equal-percentage flow characteristic (Curve 3).

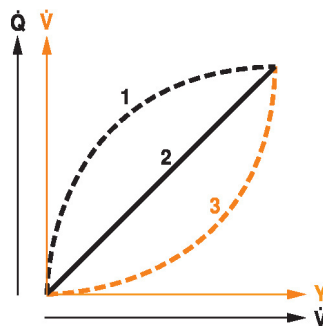

Power control Alternatively, the control signal DDC can be assigned to the output power required at the heat exchanger.

Depending on the water temperature and air conditions, the Energy Valve ensures the amount of water V' required to achieve the desired power.

Maximum controllable power on heat exchanger in power control mode:

DN 15	90 kW
DN 20	150 kW
DN 25	210 kW
DN 32	350 kW
DN 40	590 kW
DN 50	880 kW

Control characteristics The specially configured control parameters in connection with the precise velocity sensor ensure a stable quality of control. They are, however, not suitable for rapid control processes, i.e. for domestic water control.

Definition Flow control

V' nom is the maximum possible flow.

V' max is the maximum flow rate which has been set with the highest control signal DDC. V' max can be set between 25% and 100% of V' nom.

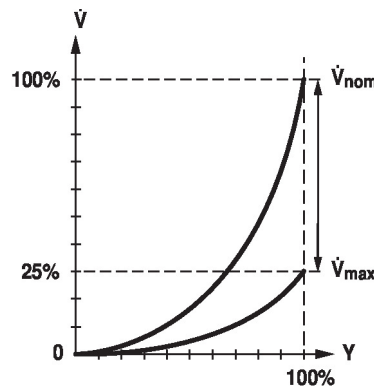

Definition Power control

Q' nom is the maximum possible power output on the heat exchanger.

Q' max is the maximum power output on the heat exchanger which has been set with the highest control signal DDC. Q' max can be set between 1% and 100% of Q' nom.

Q' min 0% (non-variable).

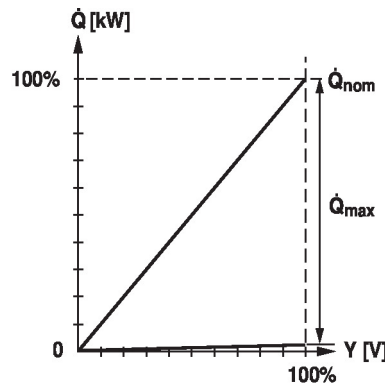

Position control In this setting, the control signal is assigned to the opening angle of the valve (e.g. $Y = 10\text{ V}$ corresponds to $\alpha = 90^\circ$). The result is a pressure-dependent operation similar to that of a conventional valve.

Creep flow suppression

Given the very low flow speed in the opening point, this can no longer be measured by the sensor within the required tolerance. This range is overridden electronically.

Opening valve

The valve remains closed until the flow required by the control signal DDC corresponds to 1% of V'nom. The control along the flow characteristic is active after this value has been exceeded.

Closing valve

The control along the flow characteristic is active up to the required flow rate of 1% of V'nom. Once the level falls below this value, the flow rate is maintained at 1% of V'nom. If the level falls below the flow rate of 0.5% of V'nom required by the control signal DDC, then the valve will close.

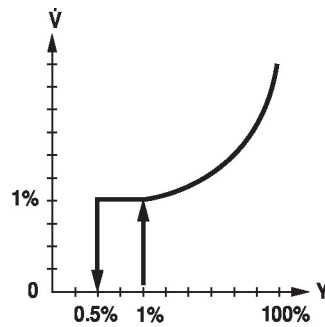

Configurable actuators

The factory settings cover the most common applications. Single parameters can be modified with the Belimo Service Tools MFT-P or ZTH EU.

Communication

The parametrisation can be carried out through the integrated web server (RJ45 connection to the web browser) or by communicative means.

Additional information regarding the integrated web server can be found in the separate documentation.

"Peer to Peer" connection

<http://belimo.local:8080>

The Notebook must be set to "DHCP".
Make sure that only one network connection is active.

Standard IP address:

<http://192.168.0.10:8080>

Static IP address

Password (read-only):

User name: «guest»

Password: «guest»

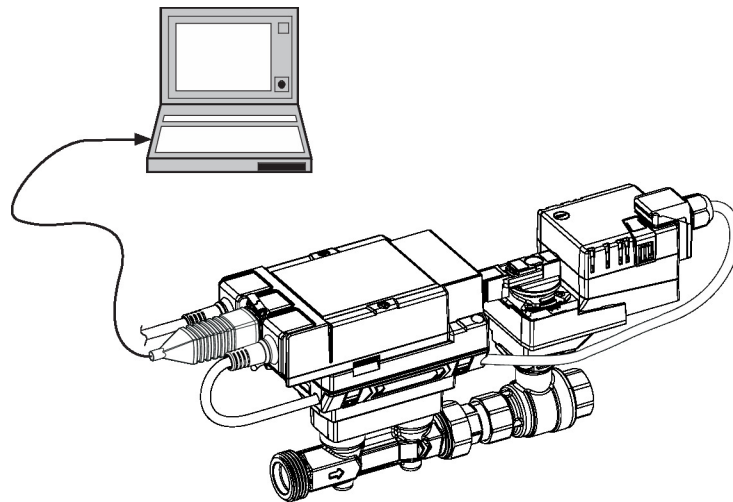

Positioning signal inversion

This can be inverted in cases of control with an analogue control signal DDC. The inversion causes the reversal of the standard behaviour, i.e. at a control signal DDC of 0%, regulation is to V'max or Q'max, and the valve is closed at a control signal DDC of 100%.

Hydronic balancing

Via the integrated web server, the maximum flow rate (equivalent to 100% requirement) can be adjusted on the device itself, simply and reliably, in a few steps. If the device is integrated in the management system, then the balancing can be handled directly by the management system.

Delta-T manager

If a heating or cooling register is operated with a differential temperature that is too low and thus with a flow rate that is too high, this will not result in an increased power output. Nevertheless, heating or cooling machines must provide the energy at a lower degree of efficiency. This means, that pumps circulate too much water and increase energy consumption unnecessarily.

With the aid of the Energy Valve, it is simple to discover that operation is being carried out at a differential temperature that is too low, resulting in the inefficient use of energy.

Necessary setting adjustments can now be carried out quickly and easily at any time. The integrated differential temperature limiting offers the user the possibility of defining a low limit value. The Energy Valve limits the flow rate automatically to prevent the level from falling below this value.

The settings of the Delta-T manager can be made either directly on the web server or via the Belimo Cloud a direct analysis of the Delta-T behavior is carried out by Belimo experts.

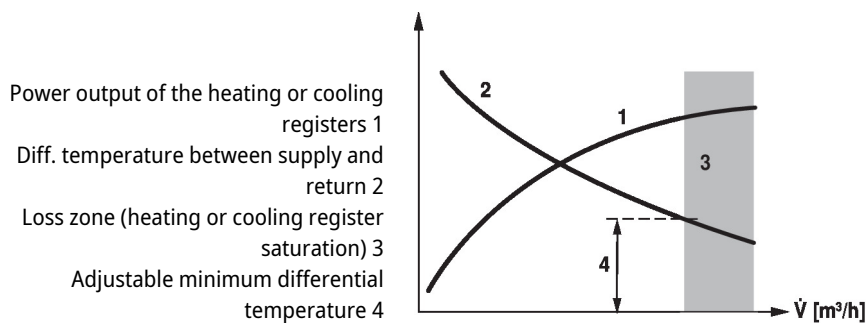

Power output of the heating or cooling registers 1
 Diff. temperature between supply and return 2
 Loss zone (heating or cooling register saturation) 3
 Adjustable minimum differential temperature 4

Combination analogue - communicative (hybrid mode)

With conventional control by means of an analogue control signal DDC, the integrated web server, BACnet, Modbus or MP-Bus can be used for the communicative position feedback.

Power and energy monitoring function

The final controlling device is equipped with two temperature sensors. A sensor (T2) is already installed at the thermal energy meter and the second sensor (T1) must be installed on-site on the other side of the water circuit. The two sensors are enclosed with the system already wired. The sensors are used to record the fluid temperature of the supply and return lines of the consumer (heating/cooling coil). As the water quantity is also known, thanks to the flow measurement integrated in the system, the power released from the consumer can be calculated. Furthermore, the heating/cooling energy is also determined automatically by means of the evaluation of the power over time.

The current data, e.g. temperatures, volumetric flow volumes, exchanger energy consumption etc. can be recorded and accessed at any time by means of web browsers or communication.

Data recording

The recorded data (integrated data recording for 13 months) can be used for the optimisation of the overall system and for the determination of the performance of the consumer (heating/cooling coil).

Download csv files through web browser.

Belimo Cloud

Additional services are available if the Energy Valve is connected to the Belimo Cloud: for instance, several devices may be managed via Internet. Also, Belimo experts may help analyse the delta-T behaviour or provide written reports about the Energy Valve performance. Under certain conditions, the product warranty according to the applicable Terms and Conditions of Sale may be prolonged. The "Terms of Use for Belimo Cloud Services" in their currently valid version apply to the use of Belimo Cloud services. Further details may be found under [www.belimo.com/ext-warranty]

Glycol monitoring

Glycol monitoring measures the actual glycol content, which is necessary for safe operation and optimised heat exchange.

Manual override

Manual override with push-button possible (the gear is disengaged for as long as the button is pressed or remains locked).

High functional safety

The actuator is overload protected, requires no limit switches and automatically stops when the end stop is reached.

Scope of delivery

Scope of delivery	Description	Type
	Grommet for RJ connection module with clamp	A-22PEM-A04
	Thermowell Stainless steel, 50 mm, G1/4", SW17	A-22PE-A07

Accessories

Spare parts	Description	Type
	Sensor module thermal energy meter DN 15	R-22PE-0UC
	Sensor module thermal energy meter DN 20	R-22PE-0UD
	Sensor module thermal energy meter DN 25	R-22PE-0UE
	Sensor module thermal energy meter DN 32	R-22PE-0UF
	Sensor module thermal energy meter DN 40	R-22PE-0UG
	Sensor module thermal energy meter DN 50	R-22PE-0UH
Gateways	Description	Type
	Converter M-Bus	G-22PEM-A01
Mechanical accessories	Description	Type
	Pipe connector for ball valve DN 15	ZR2315
	Pipe connector DN 15 Rp 1/2, G 3/4	EXT-EF-15F
	T-piece with thermowell DN 15	A-22PE-A01
	Thermowell Stainless steel, 80 mm, G1/2", SW27	A-22PE-A08
	Valve neck extension for ball valve DN 15...50	ZR-EXT-01
	Pipe connector for ball valve DN 20	ZR2320
	Pipe connector DN 20 Rp 3/4, G 1	EXT-EF-20F
	T-piece with thermowell DN 20	A-22PE-A02
	Pipe connector for ball valve DN 25	ZR2325
	Pipe connector DN 25 Rp 1, G 1 1/4	EXT-EF-25F
	T-piece with thermowell DN 25	A-22PE-A03
	Pipe connector for ball valve DN 32	ZR2332
	Pipe connector DN 32 Rp 1 1/4, G 1 1/2	EXT-EF-32F
	T-piece with thermowell DN 32	A-22PE-A04
	Pipe connector for ball valve DN 40	ZR2340
	Pipe connector DN 40 Rp 1 1/2, G 2	EXT-EF-40F
	T-piece with thermowell DN 40	A-22PE-A05
	Pipe connector for ball valve DN 50	ZR2350
	Pipe connector DN 50 Rp 2, G 2 1/2	EXT-EF-50F
	T-piece with thermowell DN 50	A-22PE-A06
Service tools	Description	Type
	Converter Bluetooth / NFC	ZIP-BT-NFC

Electrical installation

Supply from isolating transformer.

Parallel connection of other actuators possible. Observe the performance data.

The wiring of the line for BACnet MS/TP / Modbus RTU is to be carried out in accordance with applicable RS485 regulations.

Modbus / BACnet: Supply and communication are not galvanically isolated. Connect earth signal of the devices with one another.

Sensor connection: An additional sensor can optionally be connected to the thermal energy meter. This can be a passive resistance sensor Pt1000, Ni1000, NTC10k (10k Ω), an active sensor with output DC 0...10 V or a switching contact. Thus the analogue signal of the sensor can be easily digitised with the thermal energy meter and transferred to the corresponding bus system.

Analogue output: An analogue output (wire 5) is available on the thermal energy meter. It can be selected as DC 0...10 V, DC 0.5...10 V or DC 2...10 V. For example, the flow rate or the temperature of the temperature sensor T1/T2 can be output as an analogue value.

Conventional operation

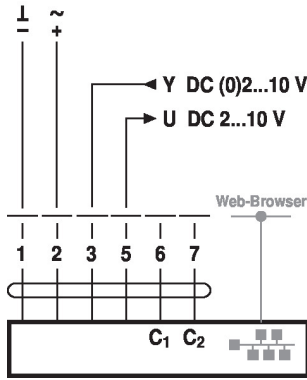

Cable colours:

- 1 = black
- 2 = red
- 3 = white
- 5 = orange
- 6 = pink
- 7 = grey

BACnet IP / Modbus TCP

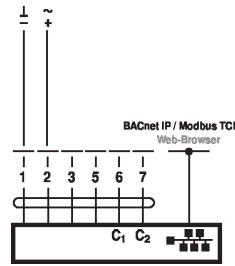

PoE with BACnet IP / Modbus TCP

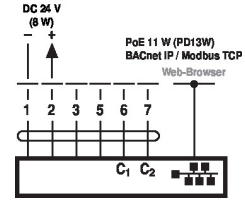

BACnet MS/TP / Modbus RTU

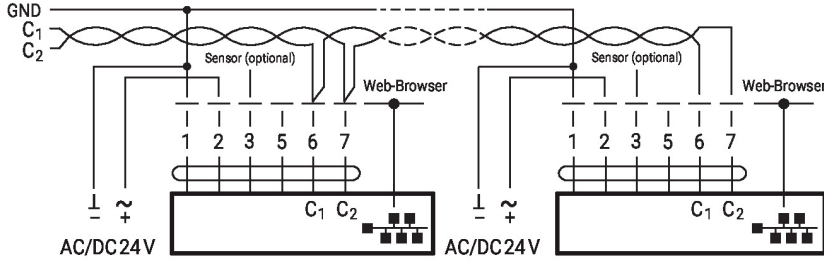

$C_1 = D - A$
 $C_2 = D + B$

Connection with active sensor

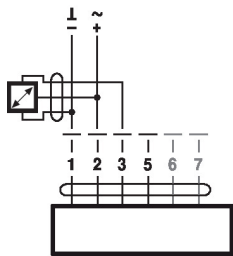

Connection with switching contact

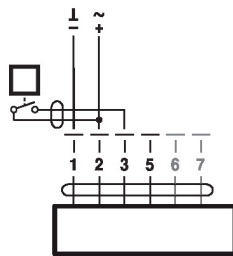

Connection with passive sensor

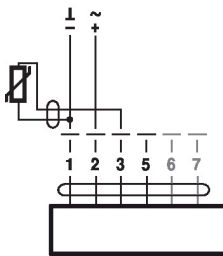

Functions

Functions with specific parameters (Parametrisation necessary)

MP-Bus, supply via 3-wire connection

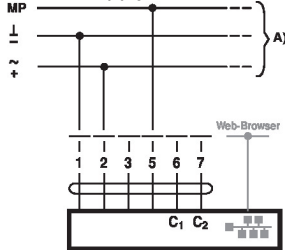

A) additional MP-Bus nodes (max. 8)

MP-Bus via 2-wire connection, local power supply

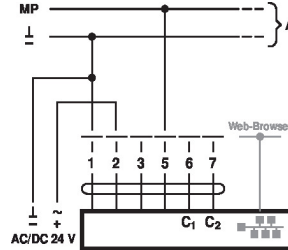

A) additional MP-Bus nodes (max. 8)

M-Bus with converter

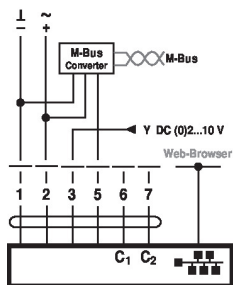

MP-Bus with analog setpoint (hybrid mode)

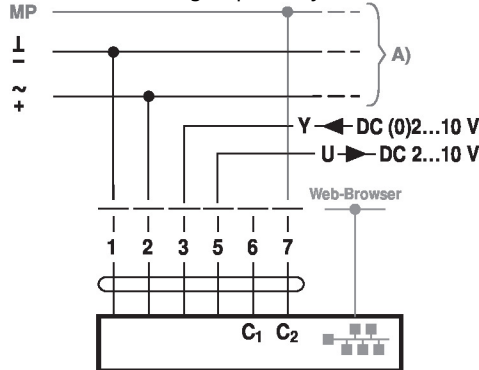

BACnet MS/TP / Modbus RTU with analog setpoint (hybrid mode)

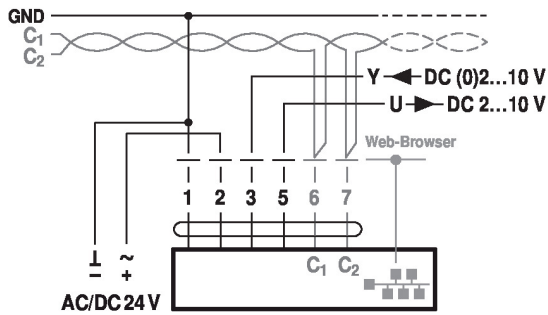

BACnet IP / Modbus TCP with analog setpoint (hybrid mode)

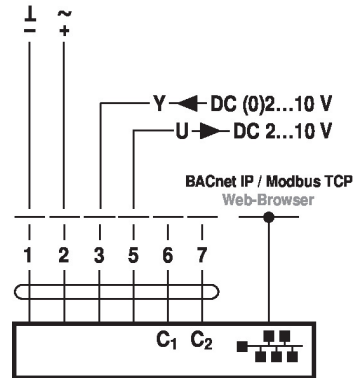

Override control and limiting with DC 24 V with relay contacts (with conventional control or hybrid mode)

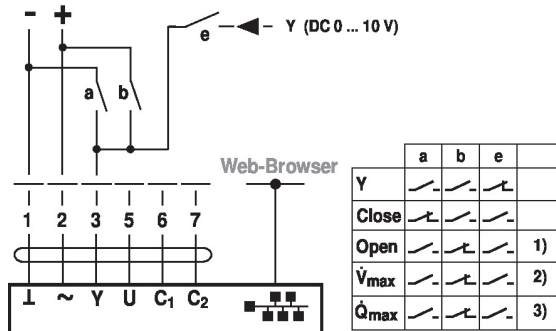

- 1) Position control
- 2) Flow control
- 3) Power control

Operating controls and indicators

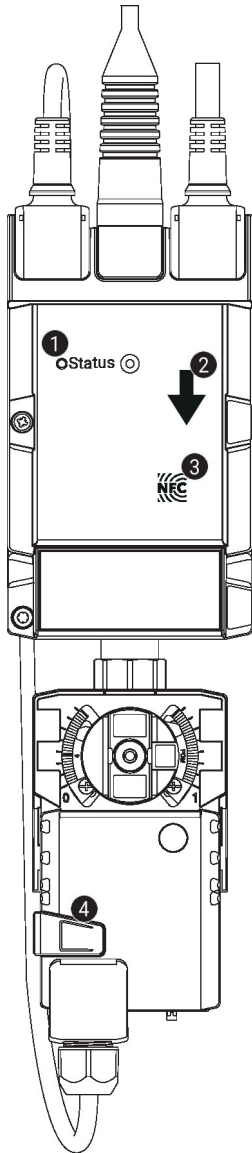

1 LED display green

- On: In operation (Power ok)
- Off: No power
- Flashing: Action needed with Belimo Assistant App

2 Flow direction

3 NFC interface

4 Gear disengagement button

- Press button: Gear disengages, motor stops, manual override possible
- Release button: Gear engages, standard mode

Installation notes

Recommended installation positions The ball valve can be installed upright to horizontal. The ball valve may not be installed in a hanging position, i.e. with the spindle pointing downwards.

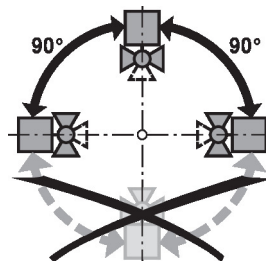

Installation position in return Installation in the return is recommended.

Water quality requirements The water quality requirements specified in VDI 2035 must be adhered to.

Belimo valves are regulating devices. For the valves to function correctly in the long term, they must be kept free from particle debris (e.g. welding beads during installation work). The installation of a suitable strainer is recommended.

Servicing Ball valves, rotary actuators and sensors are maintenance-free.
 Before any service work on the final controlling device is carried out, it is essential to isolate the rotary actuator from the power supply (by unplugging the electrical cable if necessary). Any pumps in the part of the piping system concerned must also be switched off and the appropriate slide valves closed (allow all components to cool down first if necessary and always reduce the system pressure to ambient pressure level).
 The system must not be returned to service until the ball valve and the rotary actuator have been correctly reassembled in accordance with the instructions and the pipeline has been refilled by professionally trained personnel.

Flow direction The direction of flow, specified by an arrow on the housing, is to be complied with, since otherwise the flow rate will be measured incorrectly.

Cleaning of pipes Before installing the thermal energy meter, the circuit must be thoroughly rinsed to remove impurities.

Prevention of stresses The thermal energy meter must not be subjected to excessive stress caused by pipes or fittings.

Inlet section In order to achieve the specified measuring accuracy, a flow-calming section or inflow section in the direction of the flow is to be provided upstream from the flow sensor. Its dimensions should be at least 5x DN.

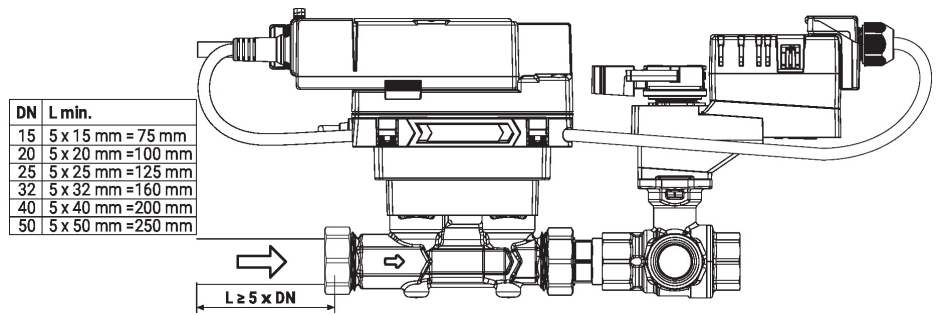

Mounting of immersion sleeve and temperature sensor The valve is equipped with two fully-wired temperature sensors.

- T2: This sensor is installed in the thermal energy meter.
- T1: This sensor is installed on site ahead of the consumer (valve in the return line) or after the consumer (valve in the supply line).

Note
 The cables between valve unit and temperature sensors may not be either shortened or lengthened.

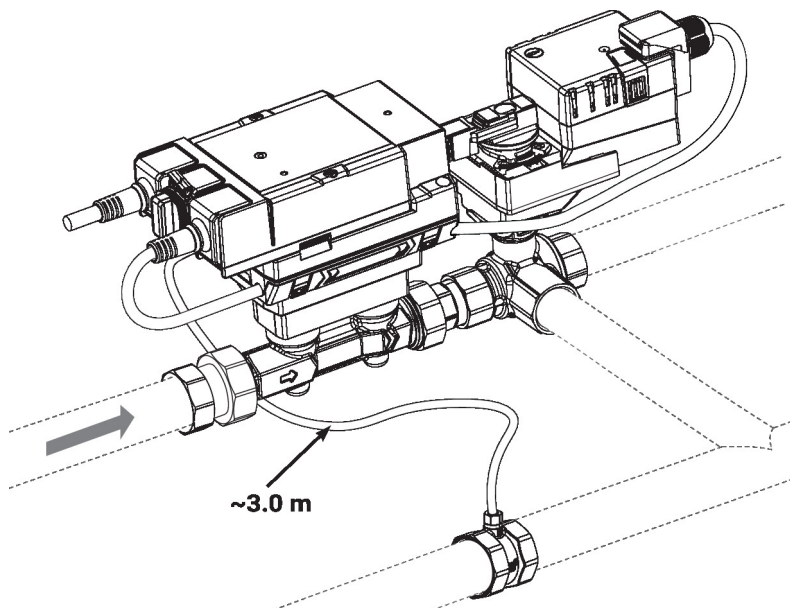

General notes
Minimum differential pressure (pressure drop)

The minimum required differential pressure (pressure drop through the valve) for achieving the desired volumetric flow V'max can be calculated with the aid of the theoretical kvs value (see type overview) and the below-mentioned formula. The calculated value is dependent on the required maximum volumetric flow V'max. Higher differential pressures are compensated for automatically by the valve.

Formula

$$\Delta p_{\min} = 100 \times \left(\frac{\dot{V}_{\max}}{k_{vs \text{ theor.}}} \right)^2$$

$\Delta p_{\min}: \text{kPa}$
 $\dot{V}_{\max}: \text{m}^3/\text{h}$
 $k_{vs \text{ theor.}}: \text{m}^3/\text{h}$

Example (DN 25 with the desired maximum flow rate = 50% V'nom)

EV025R3+BAC
 kvs theor. = 8.6 m³/h
 V'nom = 58.3 l/min
 50% * 58.3 l/min = 29.15 l/min = 1.75 m³/h

$$\Delta p_{\min} = 100 \times \left(\frac{\dot{V}_{\max}}{k_{vs \text{ theor.}}} \right)^2 = 100 \times \left(\frac{1.75 \text{ m}^3/\text{h}}{8.6 \text{ m}^3/\text{h}} \right)^2 = 4.1 \text{ kPa}$$

Behaviour in case of sensor failure

In case of a flow sensor error, the Energy Valve will switch from either power or flow control to position control (Delta-T manager will be deactivated).

Once the error disappears, the Energy Valve will switch back to the normal control setting (Delta-T manager activated)

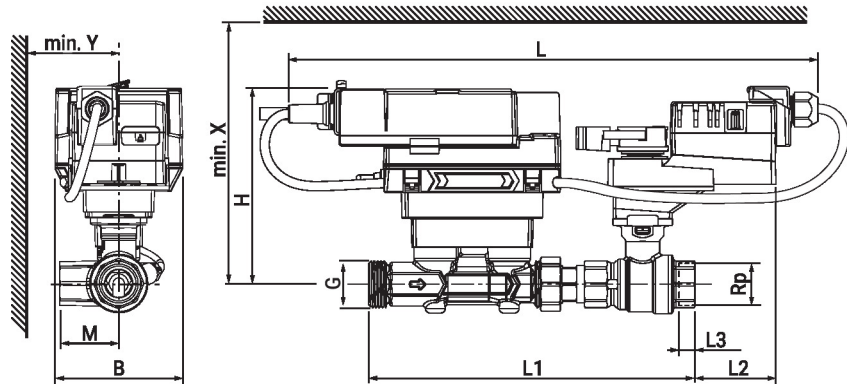
Dimensions
Dimensional drawings

Type	DN	Rp ["]	G ["]	L [mm]	L1 [mm]	L2 [mm]	L3 [mm]	B [mm]	H [mm]	M [mm]	X [mm]	Y [mm]	kg
EV015R3+BAC	15	1/2	3/4	200	190	65	13	90	136	36	206	80	2.1
EV020R3+BAC	20	3/4	1	229	227	61	14	90	137	41.5	207	80	2.8
EV025R3+BAC	25	1	1 1/4	245	240	52	16	90	140	45	210	80	2.7
EV032R3+BAC	32	1 1/4	1 1/2	263	267	54	19	90	143	55.5	213	80	4.0
EV040R3+BAC	40	1 1/2	2	300	292	52	19	90	147	66.5	217	80	4.8
EV050R3+BAC	50	2	2 1/2	309	311	43	22	90	152	79	222	80	5.2

Further documentation

- Data sheet thermal energy meter
- Overview MP Cooperation Partners
- Tool connections
- General notes for project planning
- Instruction Webserver
- Description Data-Pool Values
- BACnet Interface description
- Modbus Interface description
- Introduction to MP-Bus Technology