

Rotary actuator fail-safe for butterfly valves

- Torque motor 160 Nm (parametrised for D6250W/WL)
- Nominal voltage AC 24...240 V / DC 24...125 V
- Control modulating, communicative, hybrid
- with 2 integrated auxiliary switches
- Conversion of sensor signals
- Communication via BACnet MS/TP, Modbus RTU, Belimo-MP-Bus or conventional control

**Technical data**

<b>Electrical data</b>	Nominal voltage	AC 24...240 V / DC 24...125 V
	Nominal voltage frequency	50/60 Hz
	Nominal voltage range	AC 19.2...264 V / DC 19.2...137.5 V
	Power consumption in operation	52 W
	Power consumption in rest position	9 W
	Power consumption for wire sizing	with 24 V 54 VA / with 240 V 68 VA
	Power consumption for wire sizing note	Imax 20 A @ 5 ms
	Auxiliary switch	2 x SPDT, 1 x 10° / 1 x 0...90° (default setting 85°)
	Switching capacity auxiliary switch	1 mA...3 A (0.5 A inductive), AC 250 V
	Connection supply	Terminals 2.5 mm <sup>2</sup>
	Connection protective earth	earth terminal
	Connection control	Terminals 1.5 mm <sup>2</sup>
	Connection auxiliary switch	Terminals 2.5 mm <sup>2</sup>
	Parallel operation	Yes (note the performance data)
<b>Data bus communication</b>	Communicative control	BACnet MS/TP Modbus RTU MP-Bus
	Number of nodes	BACnet / Modbus see interface description MP-Bus max. 8
<b>Functional data</b>	Torque motor	160 Nm (parametrised for D6250W/WL)
	Operating range Y	2...10 V
	Input Impedance	100 kΩ
	Operating range Y variable	0.5...10 V 4...20 mA
	Position feedback U	2...10 V
	Position feedback U note	Max. 0.5 mA
	Position feedback U variable	0.5...10 V
	Setting fail-safe position	0...100%, adjustable with Belimo Assistant App (default setting 0%)
	Bridging time (PF)	2 s
	Bridging time (PF) variable	0...10 s
	Position accuracy	±5%
	Manual override	hand lever
	Running time motor	35 s / 90°
	Running time motor variable	30...120 s
	Running time fail-safe	30 s / 90°
	Sound power level, motor	68 dB(A)
Sound power level, fail-safe	61 dB(A)	
Position indication	Mechanically (integrated)	

<b>Safety data</b>	Protection class IEC/EN	I, protective earth (PE)
	Protection class UL	I, protective earth (PE)
	Degree of protection IEC/EN	IP66/67
	Degree of protection NEMA/UL	NEMA 4X
	Enclosure	UL Enclosure Type 4X
	EMC	CE according to 2014/30/EU
	Low voltage directive	CE according to 2014/35/EU
	Certification IEC/EN	IEC/EN 60730-1 and IEC/EN 60730-2-14
	Certification UL	cULus according to UL60730-1A, UL60730-2-14 and CAN/CSA E60730-1 The UL marking on the actuator depends on the production site, the device is UL-compliant in any case
	Mode of operation	Type 1.AA
	Rated impulse voltage supply	4 kV
	Rated impulse voltage control	0.8 kV
	Rated impulse voltage auxiliary switch	2.5 kV
	Pollution degree	3
	Ambient temperature	-30...50°C
	Storage temperature	-40...80°C
	Ambient humidity	Max. 100% RH
Servicing	maintenance-free	
<b>Weight</b>	Weight	6.5 kg
<b>Terms</b>	Abbreviations	POP = Power off position / fail-safe position CPO = Controlled power off / controlled fail-safe PF = Power fail delay time / bridging time

**Safety notes**

- This device has been designed for use in stationary heating, ventilation and air-conditioning systems and must not be used outside the specified field of application, especially in aircraft or in any other airborne means of transport.
- Caution: Power supply voltage!
- The device has a protective earthing. Incorrect connection of the protective earth can lead to hazards due to electrical shock.
- Only authorised specialists may carry out installation. All applicable legal or institutional installation regulations must be complied during installation.
- Apart from the connection box, the device may only be opened at the manufacturer's site. It does not contain any parts that can be replaced or repaired by the user.
- The device contains electrical and electronic components and must not be disposed of as household refuse. All locally valid regulations and requirements must be observed.
- The two switches integrated in the actuator are to be operated either on power supply voltage or at safety extra-low voltage. The combination power supply voltage/safety extra-low voltage is not permitted.

**Product features**

- Fields of application** The actuator is particularly suitable for utilisation in outdoor applications and is protected against the following weather conditions:
- UV radiation
  - Dirt / Dust
  - Rain / Snow
  - Air humidity

**Pre-charging time (start up)**

The capacitor actuators require a pre-charging time. This time is used for charging the capacitors up to a usable voltage level. This ensures that, in the event of a power failure, the actuator can move at any time from its current position into the preset fail-safe position.

The duration of the pre-charging time depends mainly on following factors:

- Duration of the power failure
- PF delay time (bridging time)

Typical pre-charging time

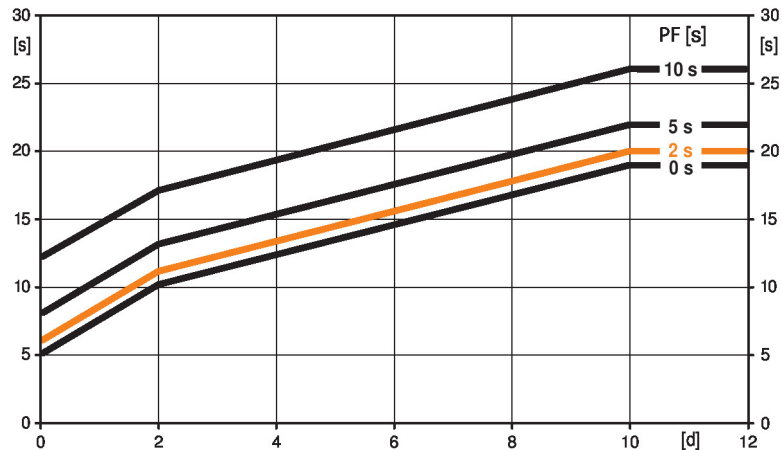

[d] = Electricity interruption in days

[s] = Pre-charging time in seconds

PF[s] = Bridging time

Calculation example: Given an electricity interruption of 3 days and a bridging time (PF) set at 5 s, the actuator requires a pre-charging time of 14 s after the electricity has been reconnected (see graphic).

PF [s]	[d]				
	0	1	2	7	≥10
0	5	8	10	15	19
2	6	9	11	16	20
5	8	11	13	18	22
10	12	15	17	22	26
	[s]				

**Delivery condition (capacitors)**

The actuator is completely discharged after delivery from the factory, which is why the actuator requires approximately 20 s pre-charging time before initial commissioning in order to bring the capacitors up to the required voltage level.

**Bridging time**

Electrical interruptions can be bridged up to a maximum of 10 s.

In the event of a power failure, the actuator will remain stationary in accordance with the set bridging time. If the power failure is greater than the set bridging time, then the actuator will move into the selected fail-safe position.

The pre-programmed bridging time is set to 2 s. This can be modified on site in operation with the use of the "Belimo Assistant App".

**Setting fail-safe position (POP)**

The desired fail-safe position can be set 0...100% with the "Belimo Assistant App" or ZTH EU. The setting always refers to the adapted angle of rotation range. In the event of a power failure, the actuator will move into the selected fail-safe position.

**Converter for sensors**

Connection option for two sensors (passive, active or switching contacts). In this way, the analogue sensor signal can be easily digitised and transferred to the bus systems BACnet or Modbus.

**Parametrisable actuators**

The factory settings cover the most common applications.

The Belimo Assistant App is required for parametrisation via Near Field Communication (NFC) and simplifies commissioning. Moreover, it provides a variety of diagnostic options.

The ZTH EU service tool provides a selection of both diagnostic and setting options.

**Combination analogue - communicative (hybrid mode)**

With conventional control by means of an analogue positioning signal, BACnet or Modbus can be used for the communicative position feedback

**Simple direct mounting**

Simple direct mounting on the butterfly valve. The mounting orientation in relation to the butterfly valve can be selected in 90° (angle) increments.

<b>Manual override</b>	The valve can be manually operated using a hand crank. Unlocking is carried out manually by removing the hand crank.
<b>Internal heating</b>	An internal heater prevents condensation buildup. Thanks to the integrated temperature and humidity sensor, the built-in heater automatically switches on/off.
<b>High functional reliability</b>	The actuator is overload protected, requires no limit switches and automatically stops when the end stop is reached.
<b>Flexible signalling</b>	The actuator has one auxiliary switch with a fixed setting (10°) and one adjustable auxiliary switch (0...90°).

**Accessories**

<b>Mechanical accessories</b>	<b>Description</b>	<b>Type</b>
	Position indicator and tappet shaft, F07, square 45° turned, SW 17, DN 125...300	ZPR01
	Tappet shaft, F07, square 45° turned, SW 17	ZPR02
	Position indicator and tappet shaft, F05, square 45° turned, SW 14, DN 80...100	ZPR03
	Hand crank for PR/PM actuator	ZPR20
<b>Service tools</b>	<b>Description</b>	<b>Type</b>
	Belimo Assistant App, Smartphone app for easy commissioning, parametrising and maintenance	Belimo Assistant App
	Converter Bluetooth / NFC	ZIP-BT-NFC
	Service Tool, with ZIP-USB function, for parametrisable and communicative Belimo actuators, VAV controller and HVAC performance devices	ZTH EU
	Connection cable 5 m, A: RJ11 6/4 ZTH EU, B: 6-pin for connection to service socket	ZK1-GEN
<b>Sensors</b>	<b>Description</b>	<b>Type</b>
	Duct/Immersion sensor Temperature 50 mm x 6 mm Pt1000	01DT-1BH
	Duct/Immersion sensor Temperature 50 mm x 6 mm Ni1000	01DT-1CH
	Duct/Immersion sensor Temperature 100 mm x 6 mm Pt1000	01DT-1BL
	Duct/Immersion sensor Temperature 100 mm x 6 mm Ni1000	01DT-1CL
	Duct/Immersion sensor Temperature 150 mm x 6 mm Pt1000	01DT-1BN
	Duct/Immersion sensor Temperature 150 mm x 6 mm Ni1000	01DT-1CN
	Duct/Immersion sensor Temperature 200 mm x 6 mm Pt1000	01DT-1BP
	Duct/Immersion sensor Temperature 200 mm x 6 mm Ni1000	01DT-1CP
	Duct/Immersion sensor Temperature 300 mm x 6 mm Pt1000	01DT-1BR
	Duct/Immersion sensor Temperature 300 mm x 6 mm Ni1000	01DT-1CR
	Duct/Immersion sensor Temperature 450 mm x 6 mm Pt1000	01DT-1BT
	Duct/Immersion sensor Temperature 450 mm x 6 mm Ni1000	01DT-1CT

**Electrical installation**

**Caution: Power supply voltage!**

Parallel connection of other actuators possible. Observe the performance data.

The wiring of the line for BACnet MS/TP / Modbus RTU is to be carried out in accordance with applicable RS485 regulations.

### Wiring diagrams

AC 24...240 V / DC 24...125 V

Modulating control

Connection auxiliary switch

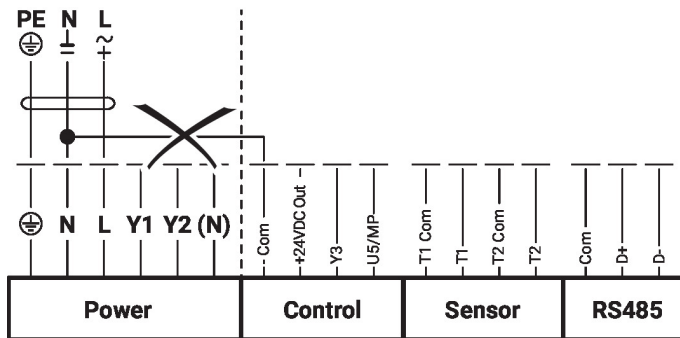
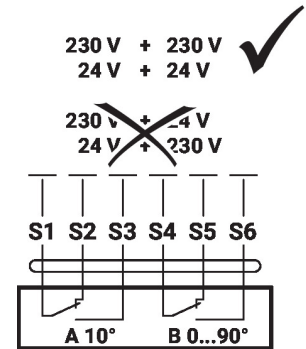
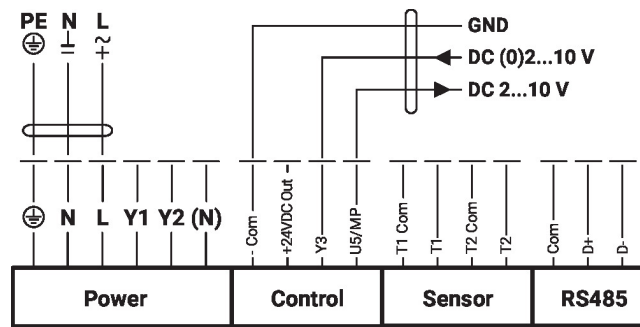
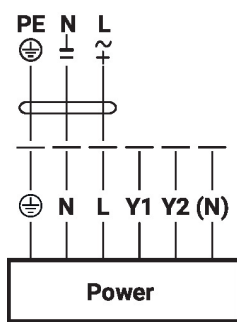

Power supply must not be connected to the signal terminals!

Parallel circuit

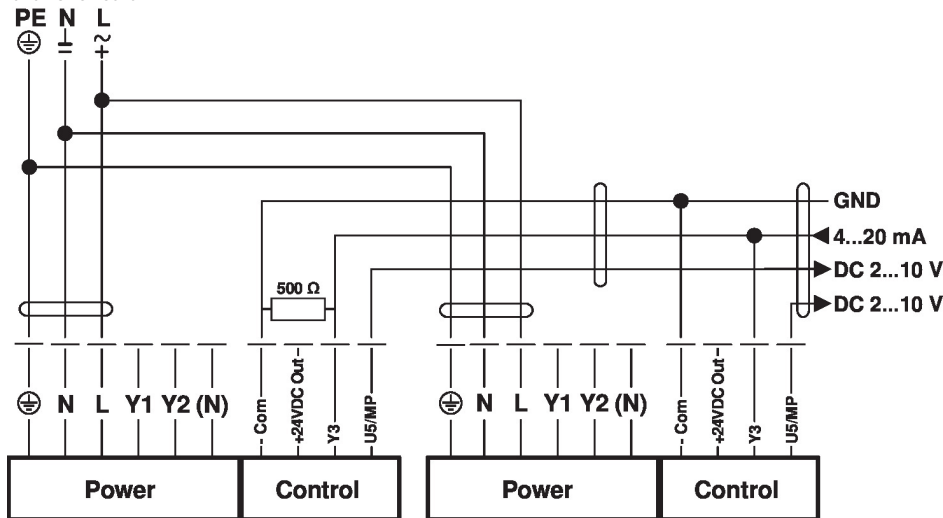

Setpoint 2...10 V

### Functions

Functions with specific parameters (NFC)

Control open/close

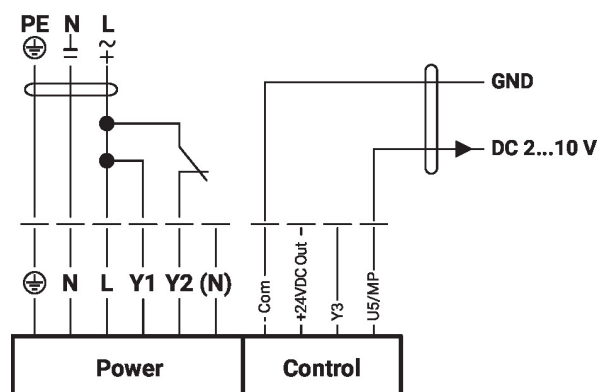
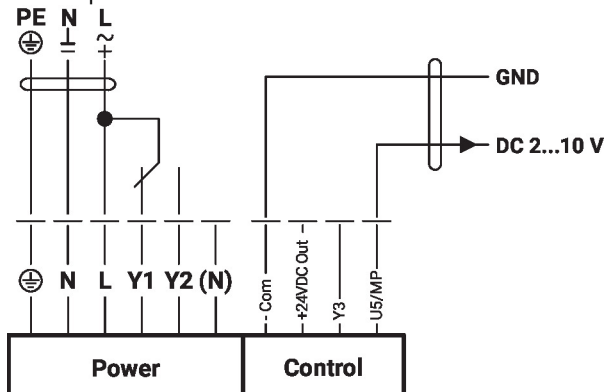

Control 3-point

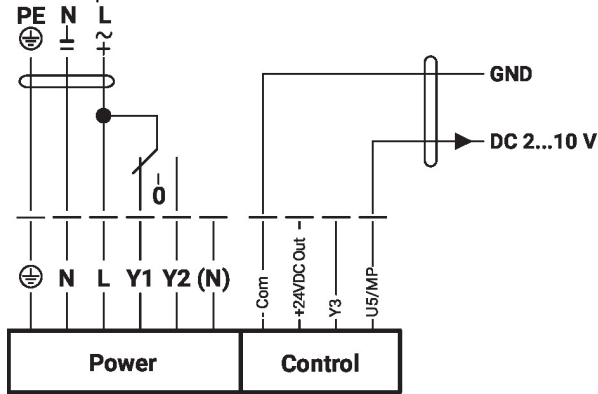

Control 4...20 mA

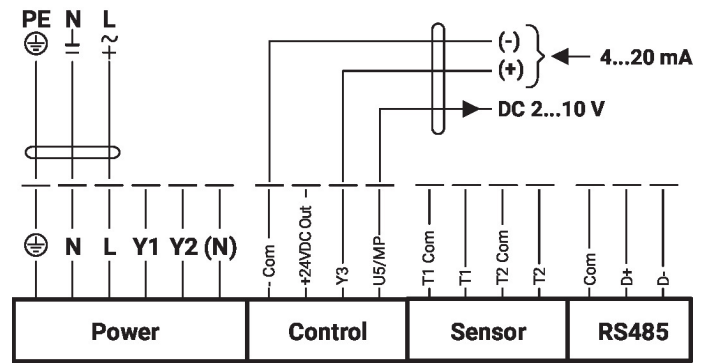

Positioner SG..

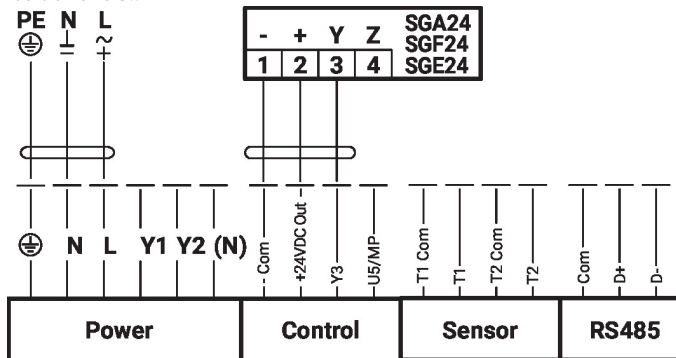

**Note**

Maximum output power «DC 24 V out» 1.2 W @ 50 mA!  
A separate safety transformer must be used for higher performance!

Connection on the MP-Bus

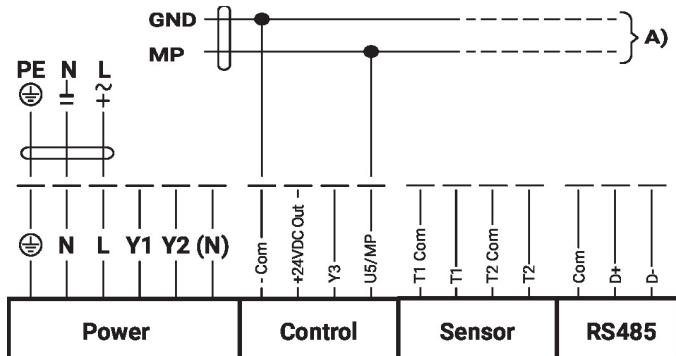

A) Additional actuators (max. 8)

MP-Bus Network topology

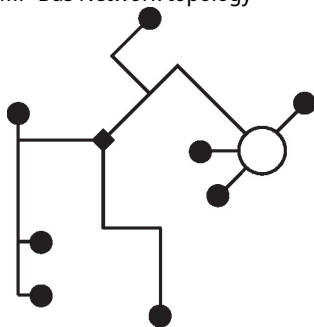

There are no restrictions for the network topology (star, ring, tree or mixed forms are permitted).  
Supply and communication in one and the same 3-wire cable

- no shielding or twisting necessary
- no terminating resistors required

Connection BACnet MS/TP / Modbus RTU

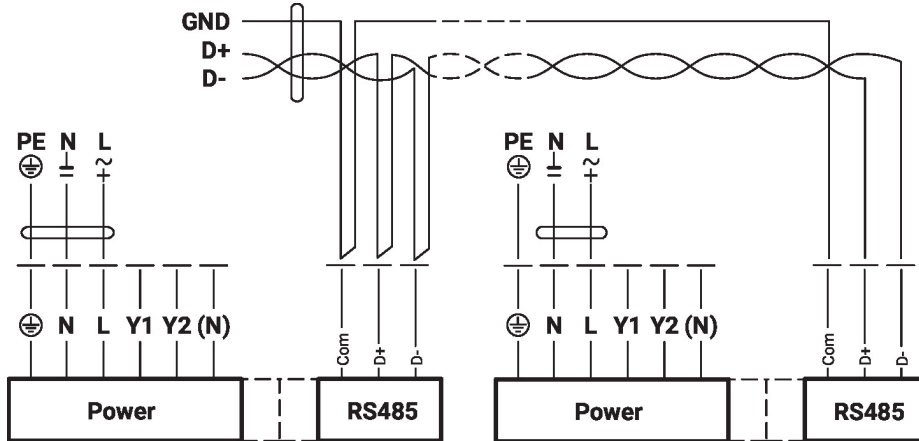

Connection BACnet MS/TP / Modbus RTU with analog setpoint (hybrid mode)

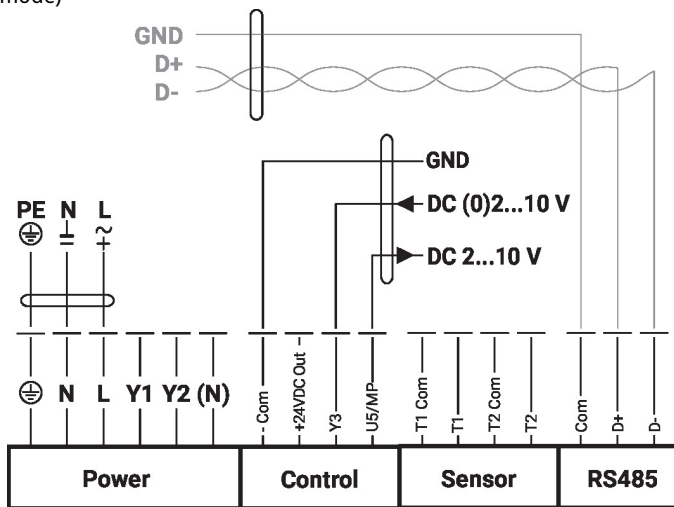

Connection of passive sensors (BACnet MS/TP / Modbus RTU)

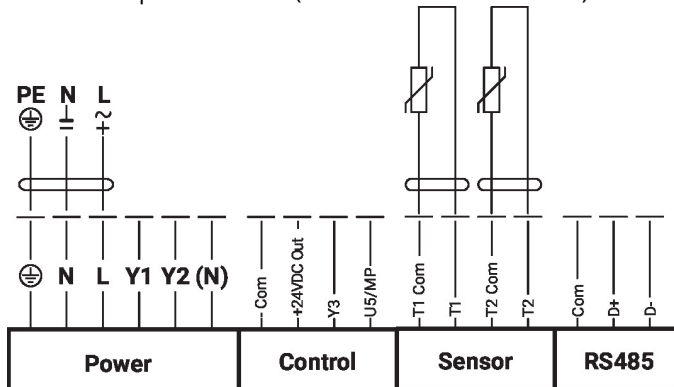

1)	2)
200 Ω...2 kΩ	0.1 Ω
2 kΩ...10 kΩ	1 Ω
10 kΩ...55 kΩ	10 Ω

- 1) Resistance range
- 2) Resolution
- Compensation of the measured value is recommended
- Suitable for Ni1000 and Pt1000
- Suitable Belimo types 01DT-..

Connection of active sensors (BACnet MS/TP / Modbus RTU)

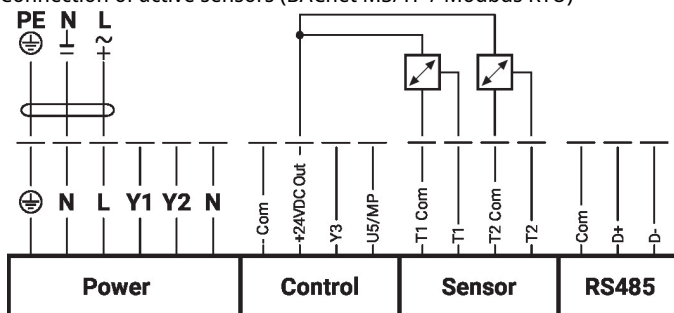

Possible input voltage range:  
DC 0...10 V (resolution 5 mV)  
For example, to capture:  
- Active temperature sensors  
- Flow sensors  
- Pressure / differential pressure sensors

Switching contact connection (BACnet MS/TP / Modbus RTU)

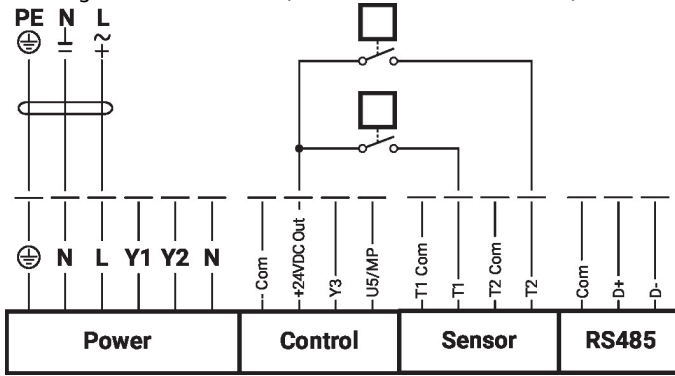

Requirements for switching contact:

The switching contact must be able to accurately switch a current of 10 mA @ 24 V.

For example, to capture:

- Flow monitors
- Operation / malfunction messages of chillers



Operating controls and indicators

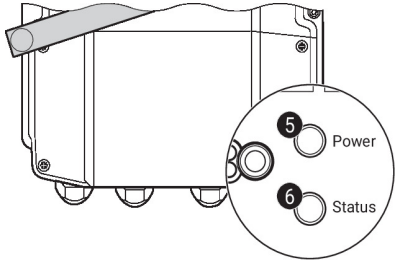

**5 Push-button and LED display green**

- Off: No power supply or malfunction
- On: In operation
- Press: Triggers test run, followed by standard mode button:

**6 Push-button and LED display yellow**

- Off: Standard mode
- On: Test run active
- Flickering: BACnet / Modbus communication active
- Flashing: Request for addressing from MP client
- Press button: Confirmation of the MP addressing

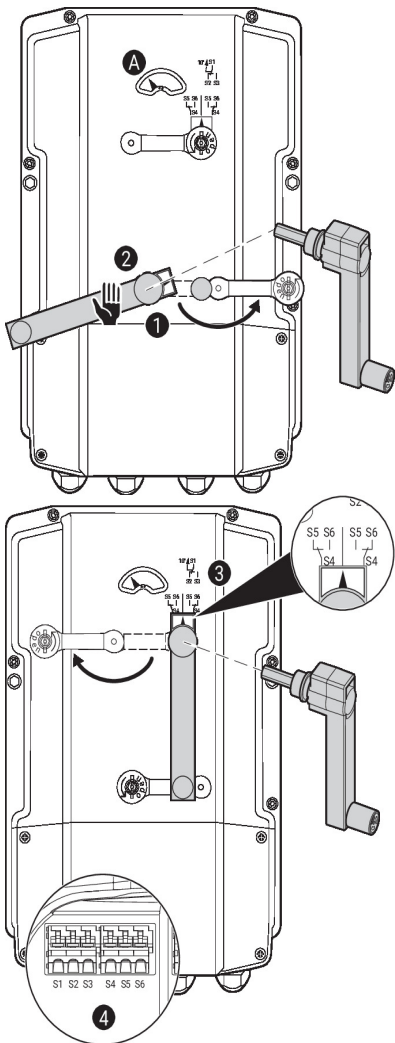

Auxiliary switch settings



**Note:** Perform settings on the actuator only in deenergised state.

For the auxiliary switch position settings, carry out points **1** to **4** successively.

**1 Gear disengagement**

Opening the manual override cover and adjusting the hand crank. Manual override is possible.

**2 Manual override control**

Turn the hand crank until the desired switching position **A** is indicated and then remove the hand crank.

**3 Auxiliary switch**

For the auxiliary switch position settings, carry out points **1** to **4** successively. Opening the auxiliary switch adjustment cover and adjusting the hand crank. Turn the hand crank until the arrow points to the vertical line.

**4 Terminals**

Connect continuity tester to S4 + S5 or to S4 + S6. If the auxiliary switch should switch in the opposite direction, rotate the hand crank by 180°.

**NFC connection** Belimo devices marked with the NFC logo can be operated with the Belimo Assistant App.

Requirement:

- NFC- or Bluetooth-capable smartphone
- Belimo Assistant App (Google Play & Apple AppStore)

Align NFC-capable smartphone on the device so that both NFC antennas are superposed.

Connect Bluetooth-enabled smartphone via the Bluetooth-to-NFC Converter ZIP-BT-NFC to the device. Technical data and operation instructions are shown in the ZIP-BT-NFC data sheet.

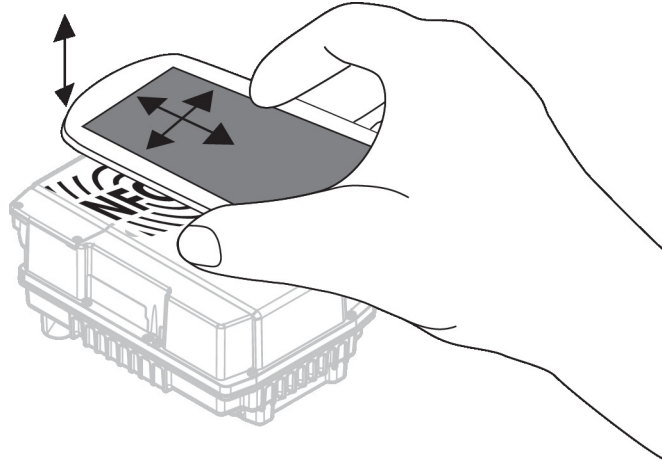

**Service tools connection** The actuator can be configured by the ZTH EU via the service socket.

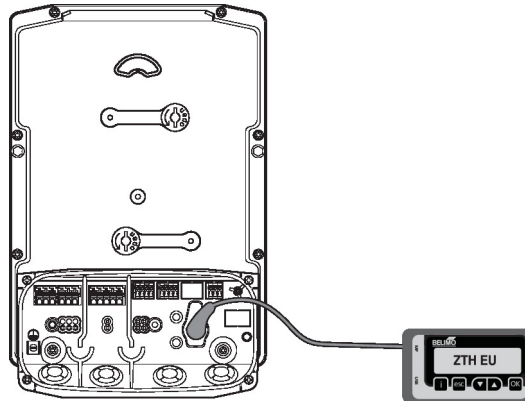

## Dimensions

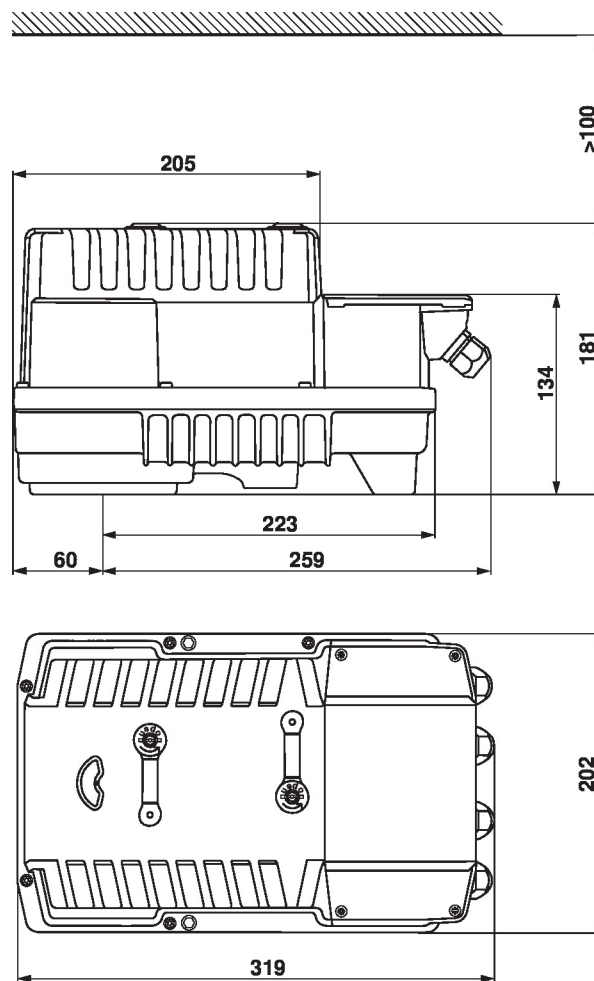

## Further documentation

- Tool connections
- Description Protocol Implementation Conformance Statement PICS
- Description Modbus register
- Overview MP Cooperation Partners
- Introduction to MP-Bus Technology
- MP Glossary
- The complete product range for water applications
- Data sheets for butterfly valves
- Installation instructions for actuators and/or butterfly valves
- General notes for project planning