

- Actuating force 2500 N
- Nominal voltage AC/DC 24 V
- Control modulating, communicative 2...10 V variable
- Stroke 50 mm
- Conversion of sensor signals
- Communication via Belimo MP-Bus



Technical data

| | | |
|------------------------|------------------------------------|---|
| Electrical data | Nominal voltage | AC/DC 24 V |
| | Nominal voltage frequency | 50/60 Hz |
| | Nominal voltage range | AC 19.2...28.8 V / DC 21.6...28.8 V |
| | Power consumption in operation | 4 W |
| | Power consumption in rest position | 1.5 W |
| | Power consumption for wire sizing | 6 VA |
| | Connection supply / control | Terminals 4 mm ² (cable Ø4...10 mm) |
| | Parallel operation | Yes (note the performance data) |
| Functional data | Actuating force motor | 2500 N |
| | Communicative control | MP-Bus |
| | Operating range Y | 2...10 V |
| | Input Impedance | 100 kΩ |
| | Operating range Y variable | Start point 0.5...30 V End point 2.5...32 V |
| | Options positioning signal | Open/close 3-point (AC only) Modulating (DC 0...32 V) |
| | Position feedback U | 2...10 V |
| | Position feedback U note | Max. 0.5 mA |
| | Position feedback U variable | Start point 0.5...8 V End point 2.5...10 V |
| | Position accuracy | ±5% |
| | Manual override | with push-button, can be locked |
| | Stroke | 50 mm |
| | Running time motor | 150 s / 40 mm (188 s / 50 mm) |
| | Running time motor variable | 113...188 s |
| | Adaptation setting range | manual (automatic on first power-up) |
| | Adaptation setting range variable | No action Adaptation when switched on Adaptation after pushing the gear disengagement button |
| | Override control | MAX (maximum position) = 100% MIN (minimum position) = 0% ZS (intermediate position, AC only) = 50% |
| | Override control variable | MAX = (MIN + 33%)...100% ZS = MIN...MAX |
| | Sound power level, motor | 56 dB(A) |
| | Position indication | Mechanically, 5...50 mm stroke |
| Safety data | Protection class IEC/EN | III, Safety Extra-Low Voltage (SELV) |
| | Power source UL | Class 2 Supply |
| | Degree of protection IEC/EN | IP54 |

| | | |
|--------------------|--|---|
| Safety data | Degree of protection NEMA/UL | NEMA 2 |
| | Enclosure | UL Enclosure Type 2 |
| | EMC | CE according to 2014/30/EU |
| | Certification IEC/EN | IEC/EN 60730-1 and IEC/EN 60730-2-14 |
| | Certification UL | cULus according to UL60730-1A, UL60730-2-14 and CAN/CSA E60730-1 The UL marking on the actuator depends on the production site, the device is UL-compliant in any case |
| | Mode of operation | Type 1 |
| | Rated impulse voltage supply / control | 0.8 kV |
| | Pollution degree | 3 |
| | Ambient temperature | 0...50°C |
| | Storage temperature | -40...80°C |
| | Ambient humidity | Max. 95% RH, non-condensing |
| | Servicing | maintenance-free |
| | Weight | Weight |

Safety notes

- This device has been designed for use in stationary heating, ventilation and air-conditioning systems and must not be used outside the specified field of application, especially in aircraft or in any other airborne means of transport.
- Outdoor application: only possible in case that no (sea) water, snow, ice, insulation or aggressive gases interfere directly with the device and that it is ensured that the ambient conditions remain within the thresholds according to the data sheet at any time.
- Only authorised specialists may carry out installation. All applicable legal or institutional installation regulations must be complied during installation.
- The switch for changing the direction of motion and so the closing point may be adjusted only by authorised specialists. The direction of motion is critical, particularly in connection with frost protection circuits.
- The device may only be opened at the manufacturer's site. It does not contain any parts that can be replaced or repaired by the user.
- The device contains electrical and electronic components and must not be disposed of as household refuse. All locally valid regulations and requirements must be observed.

Product features

| | |
|---------------------------------|---|
| Mode of operation | <p>Conventional operation:</p> <p>The actuator is connected with a standard modulating signal of 0...10 V and drives to the position defined by the positioning signal. The measuring voltage U serves for the electrical display of the actuator position 0.5...100% and as slave control signal for other actuators.</p> <p>Operation on Bus:</p> <p>The actuator receives its digital positioning signal from the higher level controller via the MP-Bus and drives to the position defined. Connection U serves as communication interface and does not supply an analogue measuring voltage.</p> |
| Converter for sensors | <p>Connection option for a sensor (passive or active sensor or switching contact). The MP actuator serves as an analogue/digital converter for the transmission of the sensor signal via MP-Bus to the higher level system.</p> |
| Parametrisable actuators | <p>The factory settings cover the most common applications. Single parameters can be modified with the Belimo Service Tools MFT-P or ZTH EU.</p> |

| | |
|---------------------------------------|--|
| Mounting on third-party valves | The retrofit actuators for installation on a wide range of valves from various manufacturers are comprised of an actuator, universal valve neck adapter and universal valve stem adapter. Adapt the valve neck and valve stem to begin with, then attach the retrofit actuator to the valve neck adapter, connect to the valve and start up. The valve neck adapter/actuator can be rotated through 360° on the valve neck, provided it is permitted by the size of the installed valve. |
| Mounting on Belimo valves | Use standard actuators from Belimo for mounting on Belimo globe valves. |
| Manual override | Manual override with push-button possible (the gear is disengaged for as long as the button is pressed or remains locked). The stroke can be adjusted by using a hexagon socket screw key (5 mm), which is inserted into the top of the actuator. The stem extends when the key is rotated clockwise. |
| High functional reliability | The actuator is overload protected, requires no limit switches and automatically stops when the end stop is reached. |
| Home position | Factory setting: Actuator stem is retracted. The first time the supply voltage is switched on, i.e. at the time of commissioning, the actuator carries out an adaptation, which is when the operating range and position feedback adjust themselves to the mechanical setting range. The actuator then moves into the position defined by the positioning signal. |
| Adaptation and synchronisation | An adaptation can be triggered manually by pressing the "Adaptation" button or with the PC-Tool. Both mechanical end stops are detected during the adaptation (entire setting range). Automatic synchronisation after pressing the gearbox disengagement button is configured. The synchronisation is in the home position (0%). The actuator then moves into the position defined by the positioning signal. A range of settings can be adapted using the PC-Tool (see MFT-P documentation) |
| Setting direction of motion | When actuated, the stroke direction switch changes the running direction in normal operation. |

Accessories

| | | |
|-------------------------------|---|-------------|
| Gateways | Description | Type |
| | Gateway MP zu BACnet MS/TP | UK24BAC |
| | Gateway MP to Modbus RTU | UK24MOD |
| Electrical accessories | Description | Type |
| | Auxiliary switch 2 x SPDT add-on | S2A-H |
| | MP-Bus power supply for MP actuators | ZN230-24MP |
| Mechanical accessories | Description | Type |
| | Spacer ring for Sauter, stroke 50 mm | ZRV-301 |
| | Spacer ring for Siebe, stroke 50 mm | ZRV-302 |
| | Spacer ring for Johnson Control, stroke 50 mm | ZRV-303 |
| | Washer Sauter for Sauter, stroke 50 mm | ZRV-304 |
| Service tools | Description | Type |
| | Service Tool, with ZIP-USB function, for parametrisable and communicative Belimo actuators, VAV controller and HVAC performance devices | ZTH EU |
| | Belimo PC-Tool, Software for adjustments and diagnostics | MFT-P |
| | Adapter for Service-Tool ZTH | MFT-C |
| | Connection cable 5 m, A: RJ11 6/4 ZTH EU, B: 6-pin for connection to service socket | ZK1-GEN |
| | Connection cable 5 m, A: RJ11 6/4 ZTH EU, B: free wire end for connection to MP/PP terminal | ZK2-GEN |

Electrical installation



Supply from isolating transformer.

Parallel connection of other actuators possible. Observe the performance data.

Direction of stroke switch factory setting: Actuator stem retracted (▲).

Wiring diagrams

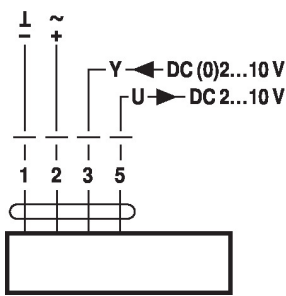
AC/DC 24 V, modulating



Operation on the MP-Bus

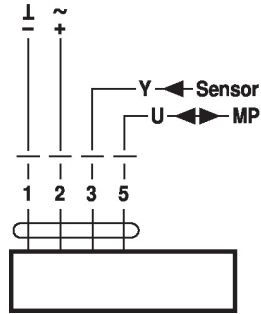

Functions

Functions when operated on MP-Bus

Connection on the MP-Bus

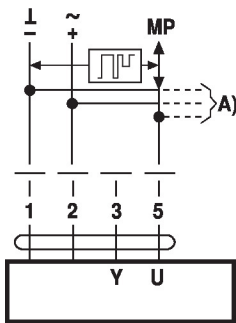

A) additional MP-Bus nodes (max. 8)

MP-Bus Network topology

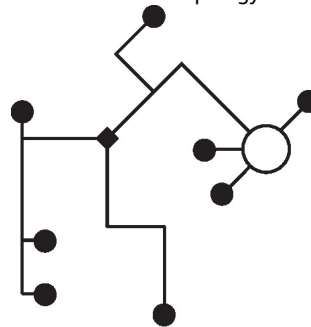

There are no restrictions for the network topology (star, ring, tree or mixed forms are permitted). Supply and communication in one and the same 3-wire cable

- no shielding or twisting necessary
- no terminating resistors required

Connection of active sensors

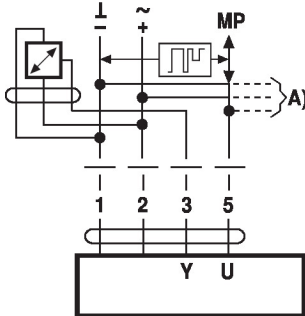

A) additional MP-Bus nodes (max. 8)

- Supply AC/DC 24 V
- Output signal DC 0...10 V (max. DC 0...32 V)
- Resolution 30 mV

Connection of external switching contact

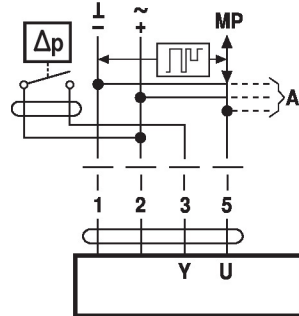

A) additional MP-Bus nodes (max. 8)

- Switching current 16 mA @ 24 V
- Start point of the operating range must be parametrised on the MP actuator as ≥ 0.5 V

Connection of passive sensors

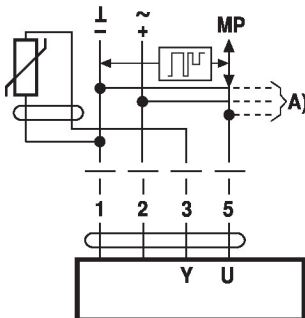

A) additional MP-Bus nodes (max. 8)

- 1) Depending on the type
- 2) Resolution 1 Ohm

Compensation of the measured value is recommended

| | | |
|--------|----------------------------|-----------------------------|
| Ni1000 | -28...+98°C | 850...1600 Ω ²⁾ |
| PT1000 | -35...+155°C | 850...1600 Ω ²⁾ |
| NTC | -10...+160°C ¹⁾ | 200 Ω...60 kΩ ²⁾ |

Functions with basic values (conventional mode)

Override control with AC 24 V with relay contacts

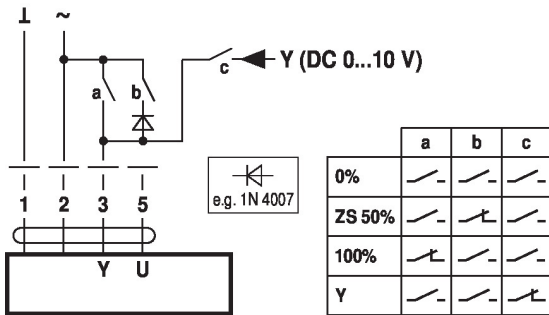

Override control with AC 24 V with rotary switch

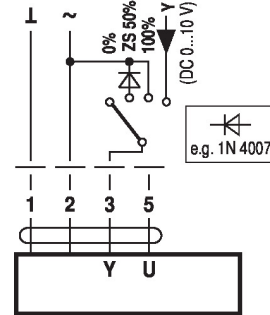

Control remotely 0...100% with positioner SG..

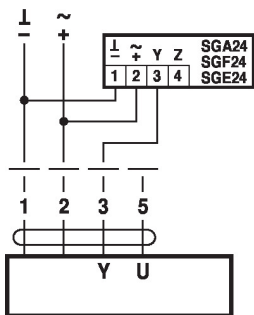

Minimum limit with positioner SG..

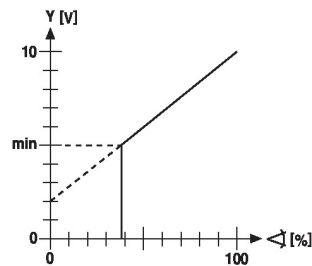
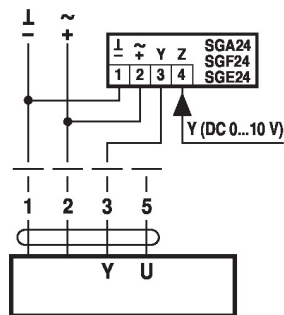

Follow-up control (position-dependent)

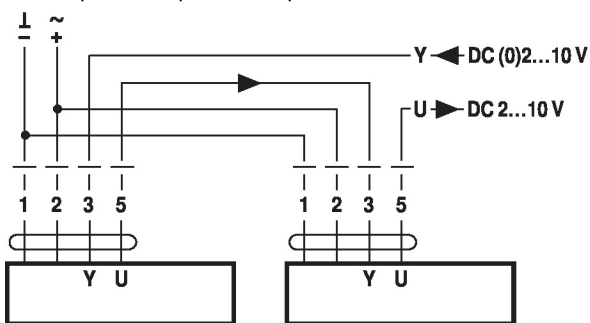

Control with 4...20 mA via external resistor

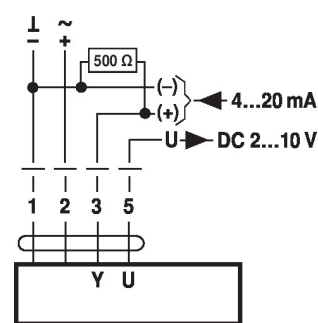

Caution:

The operating range must be set to DC 2...10 V.
The 500 Ω resistor converts the 4...20 mA current signal to a voltage signal DC 2...10 V

Functional check

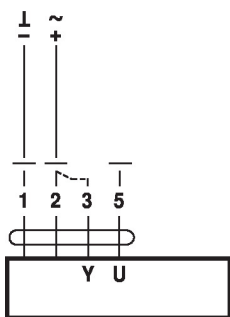

Procedure

1. Apply 24 V to connection 1 and 2
2. Disconnect connection 3:
 - with upwards direction of motion: closing point at top
 - with downwards direction of motion: closing point at bottom
3. Short circuit connections 2 and 3:
 - Actuator runs in the opposite direction

Functions for actuators with specific parameters (Parametrisation necessary)

Override control and limiting with AC 24 V with relay contacts

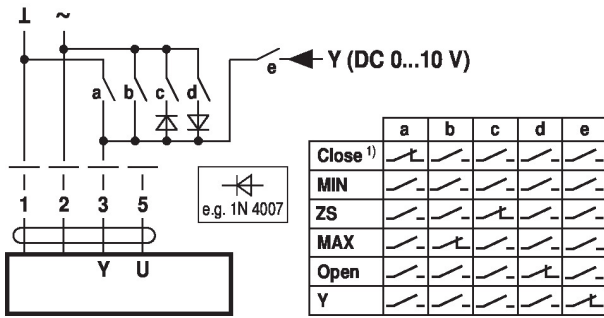

Override control and limiting with AC 24 V with rotary switch

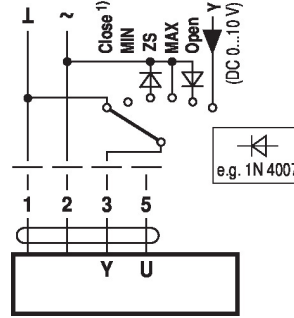

1) **Caution:** This function is only guaranteed if the start point of the operating range is defined as min. 0.5 V.

Control open/close

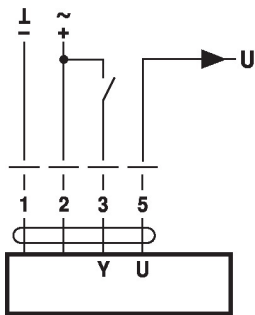

Control 3-point

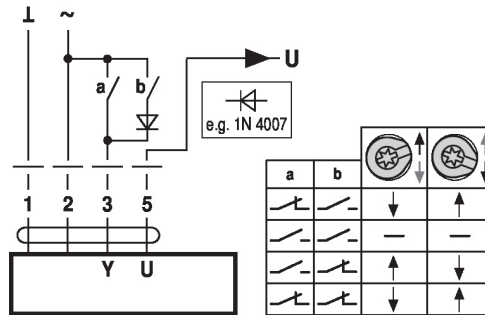

Operating controls and indicators

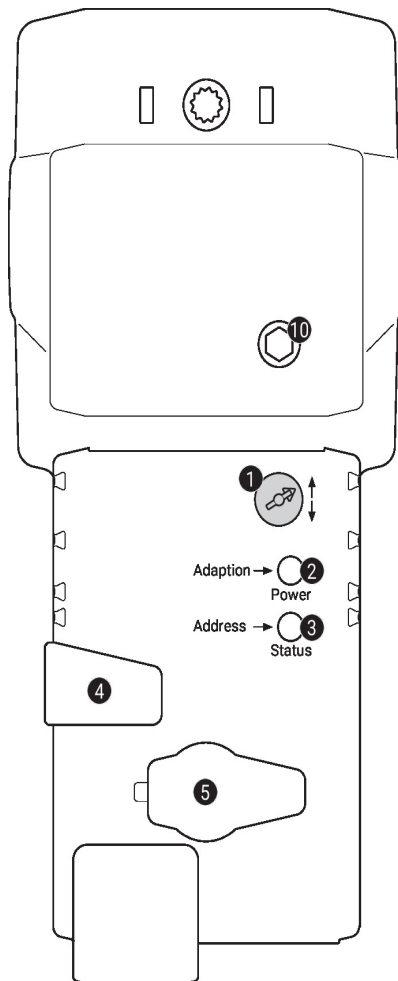

1 Direction of stroke switch

Switch over: Direction of stroke changes

2 Push-button and LED display green

Off: No power supply or malfunction
 On: In operation
 Press: Triggers stroke adaptation, followed by standard mode button:

3 Push-button and LED display yellow

Off: Standard mode
 On: Adaptation or synchronisation process active
 Flickering: MP-Bus communication active
 Flashing: Request for addressing from MP master
 Press button: Confirmation of the addressing

4 Gear disengagement button

Press button: Gear disengages, motor stops, manual override possible
 Release button: Gear engages, standard mode

5 Service plug

For connecting parametrisation and service tools

10 Manual override

Clockwise: Actuator stem extends
 Counterclockwise: Actuator stem retracts

Service

Service tools connection The actuator can be parametrised by ZTH EU via the service socket. For an extended parametrisation the PC tool can be connected.

Connection ZTH EU / PC-Tool

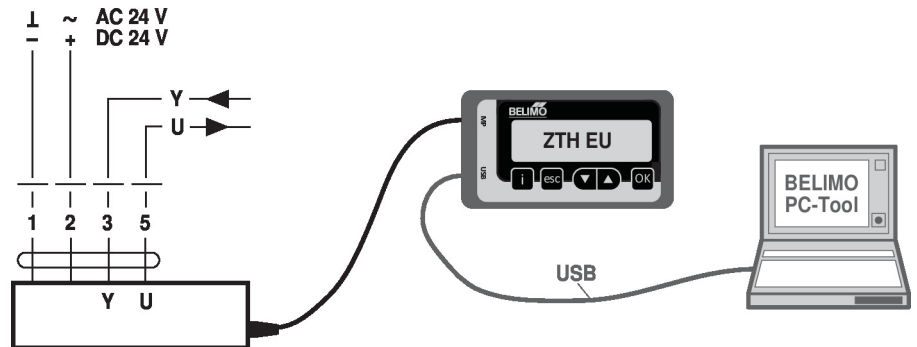

Dimensions

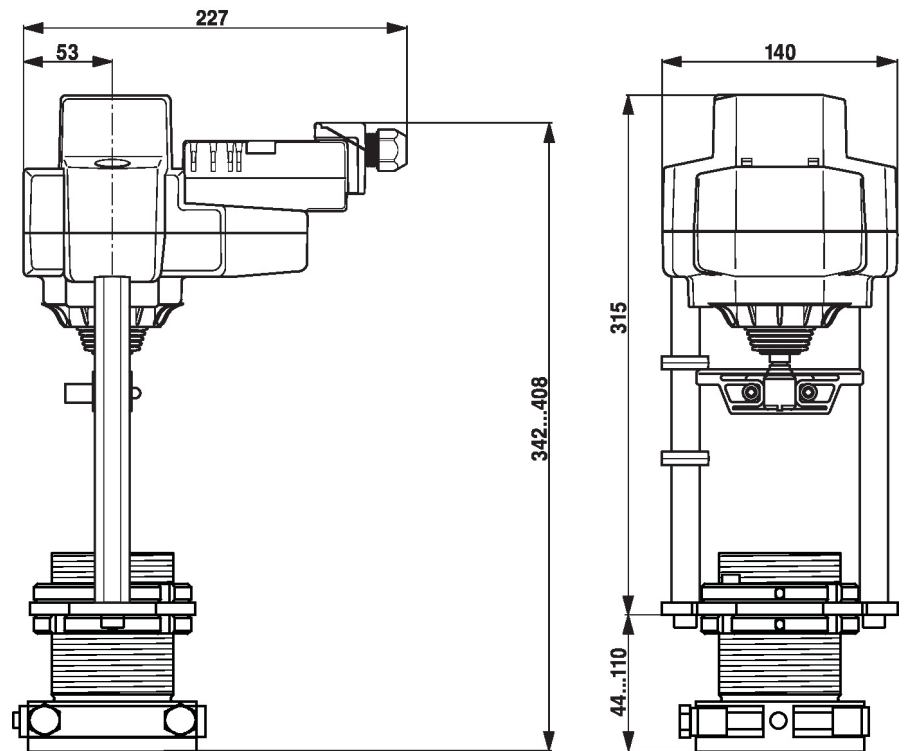

Further documentation

- Tool connections
- Introduction to MP-Bus Technology
- Overview MP Cooperation Partners
- Data sheets for globe valves
- Installation instructions for actuators