

Auxiliary switch unit, suitable for the spring-return actuators NF..A., SF..A., LF..

- two switches (SPDT)
- Adjustable switching points
- including adapter

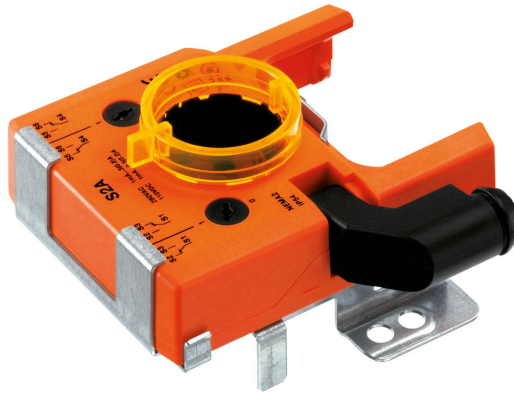

Technical data

Electrical data	Auxiliary switch	2 x SPDT, 0...100%, adjustable
	Switching capacity auxiliary switch	1 mA...3 A (0.5 A inductive), AC 250 V (II, reinforced insulation), 1 mA...0.5 A (0.2 A inductiv; L/R = 3.4 ms), DC 110 V (II, reinforced insulation)
	Switching points auxiliary switch	Adjustable across the entire range of rotation 0...1 of the actuator. Presetting with scale possible.
	Connection auxiliary switch	Cable 1 m, 6 x 0.75 mm ²
Safety data	Protection class IEC/EN	II, reinforced insulation
	Degree of protection IEC/EN	IP54
	EMC	CE according to 2014/30/EU
	Low voltage directive	CE according to 2014/35/EU
	Certification IEC/EN	IEC/EN 60730-1 and IEC/EN 60730-2-14
	Mode of operation	Type 1.B
	Pollution degree	3
	Ambient temperature	-30...50°C
	Storage temperature	-40...80°C
	Ambient humidity	Max. 95% RH, non-condensing
Servicing	maintenance-free	
Weight	Weight	0.25 kg

Safety notes



- The device must not be used outside the specified field of application, especially not in aircraft or in any other airborne means of transport.
- Outdoor application: only possible in case that no (sea) water, snow, ice, insulation or aggressive gases interfere directly with the device and that it is ensured that the ambient conditions remain within the thresholds according to the data sheet at any time.
- Only authorised specialists may carry out installation. All applicable legal or institutional installation regulations must be complied during installation.
- The device may only be opened at the manufacturer's site. It does not contain any parts that can be replaced or repaired by the user.
- Cables must not be removed from the device.
- The device contains electrical and electronic components and must not be disposed of as household refuse. All locally valid regulations and requirements must be observed.

Product features

- Mode of operation** A carrier plate uses adaptation to make a positive fit on the spring-return actuator and transfers the rotary movement directly to the feedback potentiometer.
 Switching points can be freely selected with an adjustment dial. The current switch position can be read off at any time.
- Application** The auxiliary switch unit is used for signaling the position or for exercising switching functions in any given angle setting.
- Simple direct mounting** The auxiliary switch unit is connected directly by means of adaptation with the hollow shaft (LF., NF..A., SF..A..) of the actuator. Once it is mounted, the unit is screwed to the actuator.
 The shaft clamps mounted on the bottom side.

Electrical installation

Wiring diagrams

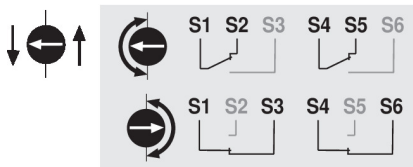
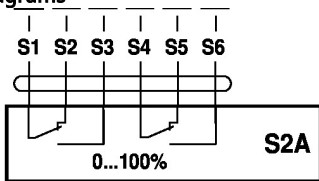

Cable colours:

- S1 = violet
- S2 = red
- S3 = white
- S4 = orange
- S5 = pink
- S6 = grey

Operating controls and indicators

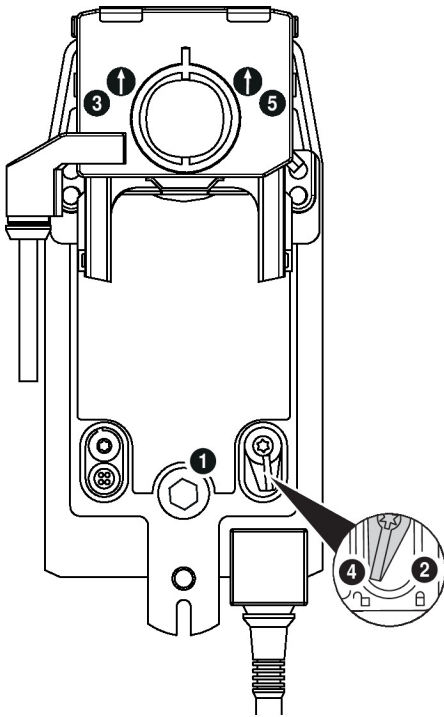

Note: Perform settings on the auxiliary switch only in deenergised state.

- 1 Manual override control**
 Turn the hand crank until the desired switching position is set.
- 2 Fasten the locking device**
 Turn the locking switch to the «Locked padlock» symbol.
- 3 Auxiliary switch 1**
 Turn rotary knob until the arrow points to the vertical line.
 The arrow direction always indicates the switching position (S1-S2 or S1-S3).
 If the auxiliary switch should switch in the opposite direction, rotate the auxiliary switch rotary knob by 180°. Alternatively the switching position can be checked with a continuity tester on the cable of the auxiliary switch.
- 4 Unlock the locking device**
 Turn the locking switch to the «Unlocked padlock» symbol or unlock with the hand crank.
- 5 Auxiliary switch 2**
 Same procedure as for auxiliary switch 1 (step **1** to **4**).

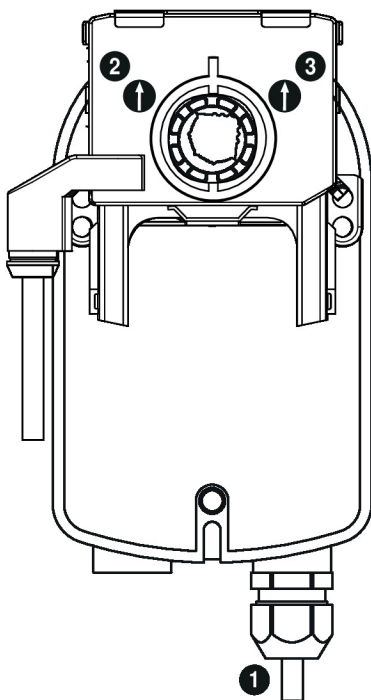

Note: Perform settings on the auxiliary switch only in deenergised state.

- 1 Manual adjusting**
 Connect the actuator and move it into the desired position.
- 2 Auxiliary switch 1**
 Turn rotary knob until the arrow points to the vertical line.
 The arrow direction always indicates the switching position (S1-S2 or S1-S3).
 If the auxiliary switch should switch in the opposite direction, rotate the auxiliary switch rotary knob by 180°. Alternatively the switching position can be checked with a continuity tester on the cable of the auxiliary switch.
- 3 Auxiliary switch - 2**
 Same procedure as for auxiliary switch 1 (step **1** to **2**).

Dimensions

Dimensional drawings

